

EUROPEAN ASSESSMENT DOCUMENT

EAD 330087-01-0601

December 2020

SYSTEMS FOR POST-INSTALLED REBAR CONNECTIONS WITH MORTAR

The reference title and language for this EAD is English. The applicable rules of copyright refer to the document elaborated in and published by EOTA.

This European Assessment Document (EAD) has been developed taking into account up-to-date technical and scientific knowledge at the time of issue and is published in accordance with the relevant provisions of Regulation (EU) 305/2011 as a basis for the preparation and issuing of European Technical Assessments (ETA).

Contents

1	Scope of the EAD	4
1.1	Description of the construction product	4
1.2	Information on the intended use(s) of the construction product	5
1.2.1	Intended use(s).....	5
1.2.2	Working life/Durability	10
1.3	Specific terms used in this EAD	11
1.3.1	Abbreviations.....	11
1.3.2	Notation	11
1.3.3	Indices	13
1.3.4	Definitions.....	14
2	Essential characteristics and relevant assessment methods and criteria	15
2.1	Essential characteristics of the product	15
2.2	Methods and criteria for assessing the performance of the product in relation to essential characteristics of the product.....	16
2.2.1	Bond strength of post-installed rebar	16
2.2.2	Bond efficiency factor	28
2.2.3	Amplification factor for minimum anchorage length (Test series Table A.1, lines 3 to 6) ...	32
2.2.4	Bond strength under seismic loading, seismic bond efficiency factor (test series S1 and S2)	34
2.2.5	Minimum concrete cover under seismic loading	38
2.2.6	Characteristic resistance to steel failure for rebar tension anchors	44
2.2.7	Bond strength at increased temperature for post-installed rebar assessed for 50 years (test series 18).....	44
2.2.8	Bond strength at increased temperature for post-installed rebar assessed for 100 years .	49
2.2.9	Characteristic resistance to steel failure for rebar tension anchors under fire exposure	49
2.2.10	Reaction to fire	50
3	Assessment and verification of constancy of performance	51
3.1	System(s) of assessment and verification of constancy of performance to be applied	51
3.2	Tasks of the manufacturer	51
3.3	Tasks of the notified body.....	52
4	Reference documents	53
Annex A	Test program and general aspects of assessment	54
Annex B	Details of tests for Injection systems with post-installed rebars	62

1 SCOPE OF THE EAD

1.1 Description of the construction product

This EAD covers post-installed reinforcing bar (rebar) connections designed in accordance with EN 1992-1-1 [1]¹ and EN 1992-1-2 [2]. The EAD deals with the preconditions, assumptions and the required tests and assessments for post-installed rebar.

The system for post-installed rebar connection comprises of a mortar and an embedded straight deformed reinforcing bar with properties according to EN 1992-1-1 [1] Annex C.

This EAD also covers post-installed rebar tension anchors. A rebar tension anchor consists of a steel element and a bonding material (mortar). The steel element may be a deformed reinforcing bar with a metric thread applied to one end (e.g., by machining) or a partly or fully threaded bolt welded to a deformed reinforcing bar. An example of a rebar tension anchor is given in Figure 1.1. The rebar tension anchor transmits forces by lapping of the post-installed rebar tension anchor (deformed reinforcing bar portion) with the existing reinforcement (laps, splices) in the concrete member. The rebar tension anchor is loaded in tension only and is used to fasten a fixture at the surface of the concrete member.

The product is not fully covered by EAD 330087-00-0601 [16].

In addition to EAD 330087-00-0601 [16] the following new assessments/essential characteristics are added:

- Post-installed rebar connection under seismic action (Development of this aspect was initiated as EAD 331522-00-0601, however the ongoing harmonisation process resulted in merging into this EAD.)
- Assessment for 100 years working life (Development of this aspect was initiated as EAD 330087-00-0601-v01, however the ongoing harmonisation process resulted in merging into this EAD.)
- Former TR 048 is included (without technical changes in the test and assessment methods)
- Editorial revision without technical changes in the assessment methods
- Assessment of rebar tension anchors

This EAD covers products which exhibit sufficiently steady load-displacement behaviour and for which the scatter in the tests does not exceed the following values:

- $cv_F \leq 20\%$ (test series line 1 to 6 according to Table A.1)
- $cv_F \leq 30\%$ (test series line 7,8,12 to 15 and line S1 and S2 and S3.2, according to Table A.1)
- $cv_\delta \leq 40\%$ (test series S1, S2 and S3.2 according to Table A.1)

where cv_F and cv_δ are the coefficients of variation for loads and displacements, respectively.

Concerning product packaging, transport, storage, maintenance, replacement and repair it is the responsibility of the manufacturer to undertake the appropriate measures and to advise his clients on the transport, storage, maintenance, replacement and repair of the product as he considers necessary.

It is assumed that the product will be installed according to the manufacturer's instructions or (in absence of such instructions) according to the usual practice of the building professionals.

Relevant manufacturer's stipulations having influence on the performance of the product covered by this European Assessment Document shall be considered for the determination of the performance and detailed in the ETA.

¹ All undated references to standards or to EADs in this document are to be understood as references to the dated versions listed in clause 4.

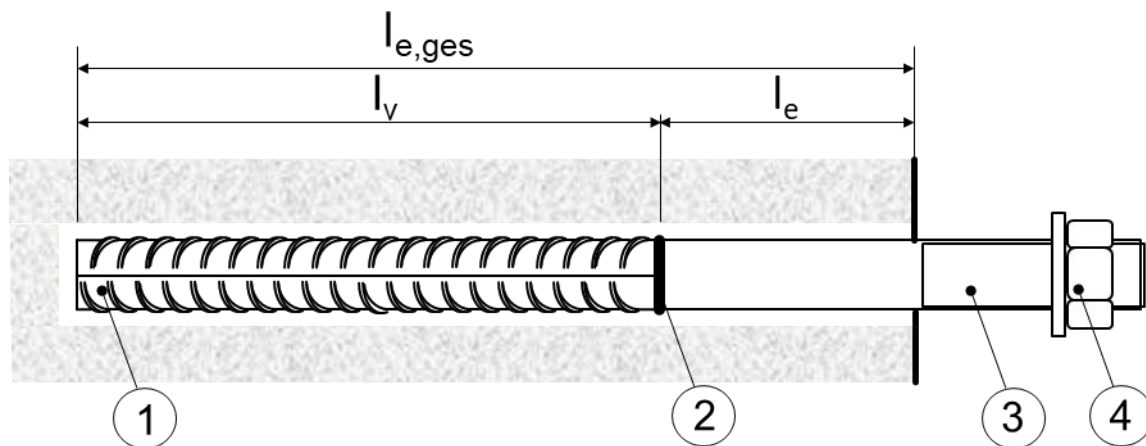

- | | |
|---|--|
| 1 | reinforcing bar according to EN 1992-1-1 [1] |
| 2 | welded joint (e.g., friction welding or resistance welding) |
| 3 | partially or fully threaded bolt made of carbon steel or stainless steel |
| 4 | washer and hexagon nut |

Figure 1.1 Rebar tension anchor (example)

1.2 Information on the intended use(s) of the construction product

1.2.1 Intended use(s)

Post-installed rebar connections are intended to be used in non-carbonated concrete C12/15 to C50/60 according to EN 206 [3], which are allowed with straight deformed cast-in bars according to EN 1992-1-1 [1]. Post-installed rebars are intended to be used for minimum design bond strength for at least concrete strength class C12/15 in accordance with EN 1992-1-1 [1] applies.

Post-installed rebar connections are intended to be used in well compacted concrete.

Overlap joints with post-installed rebar for existing cast-in rebar are intended to be used, when the position of the existing rebar is known or is determined using a rebar detector suitable for this purpose.

Detailing and load transfer are to be accounted for as given in EN 1992-1-1 [1]. Examples for such rebar connections are as follows (considering the Note to Figures 1.2 to 1.6):

- an overlapping joint with existing reinforcement in a building component, see Figure 1.2 and Figure 1.3;
- anchoring of the reinforcement at a slab or beam support; end support/bearing of a slab designed as simply supported as well as its reinforcement for restraint forces, see Figure 1.4;
- anchoring of reinforcement of building components stressed primarily in compression, see Figure 1.5;
- anchoring of reinforcement to cover the line of acting tensile force, see Figure 1.6.

Actions

Application of post-installed rebar connections are intended to be used in structures subject to static or quasi-static actions as well as to fire exposure and seismic action. Post-installed rebar connections in structures loaded by fatigue are beyond the scope of this EAD.

Rebar tension anchors are loaded by static or quasi-static normal forces only (axial tension).

Application

In this EAD the assessment is made to determine performances of post-installed rebar connections which are needed as inputs for calculation of mechanical resistance for design according to EN 1992-1-1 [1] (for static and quasi-static action) and for resistance to fire according to EN 1992-1-2 [2] and for resistance to seismic action according to EN 1998-1 [9].

In this EAD the assessment is made to determine performances of rebar tension anchors with respect to calculation of steel failure in structures under tension load according to EN 1992-4 [11], Annex D.

This EAD is applicable for post-installed rebar connections, where the mean bond resistance $f_{bm} \geq 7,1$ N/mm² for all rebar diameters. The requirement accounts for the lowest concrete strength class C12/15 in accordance with EN 1992-1-1 [1] (see also 2.2.1 of this EAD).

Installation:

- D1 = Installation direction downward only,
 D2 = Installation direction downward and horizontal installation
 D3 = Installation direction downward and horizontal and upwards (e.g., overhead) installation

Installation in water-filled hole is not covered by this EAD.

Concrete temperature range in service condition

The covered service temperature range of the concrete during the working life is specified by the manufacturer and given as intended use in the ETA.

- T1: 24°C/40°C = temperature range from -40°C to +40°C, with a maximum long-term temperature of +24°C, and a maximum short-term temperature of +40°C;
 T2: 50°C/80°C = temperature range from -40°C to +80°C, with a maximum long-term temperature of +50°C, and a maximum short-term temperature of +80°C;
 T3: T_{lt}/T_{st} = possible other or additional temperature range from -40°C to + T_{st} , with a maximum long-term temperature $T_{mit} = 0,6$ to $1,0 T_{st}$, and a maximum short-term temperature of $T_{mst} \geq 40^\circ\text{C}$ if applied for by the manufacturer

Note 1 The maximum short-term temperature T_{st} and the maximum long-term temperature T_{lt} for different temperature range as given in T1 and T2 may be chosen by the manufacturer.

If no temperature range is specified by the manufacturer, the service temperature T1 is to be assumed.

Durability

Corrosion resistance

Maximum allowable chloride contents of the concrete for the intended use according to EN 206 [3], Table 15.

- Cl 0,20
- Cl 0,40

The maximum allowable chloride contents depend on the intended use and is given by the manufacturer. If no allowable chloride content is specified by the manufacturer, the allowable chloride content Cl 0,20 is to be assumed.

Corrosion resistance of rebar tension anchors:

The assessment/testing required with respect to corrosion resistance will depend on the specification of the rebar tension anchors in relation to its use. Supporting evidence that corrosion will not occur is not required if the steel parts of the metal fastener are protected against corrosion, as set out below:

- (1) rebar tension anchors intended for use in structures subject to dry, internal conditions:
No special corrosion protection is necessary for steel parts as coatings provided for preventing corrosion during storage prior to use and for ensuring proper functioning (zinc coating with a minimum thickness of 5 microns) is considered sufficient.
- (2) Rebar tension anchors for use according EN 1993-1-4 [10], Annex A:

Rebar tension anchors with a threaded part made of stainless steel according to Tables A.3 and A.4 in Annex A of EN 1993-1-4 [10] are considered to have sufficient durability for the corresponding Corrosion Resistance Class (CRC), if the part made of stainless steel which is free of annealing colours is embedded at least 5 cm deep into the concrete (i.e., welded joint at least 5 cm from concrete surface).

Examples of post-installed rebar connections

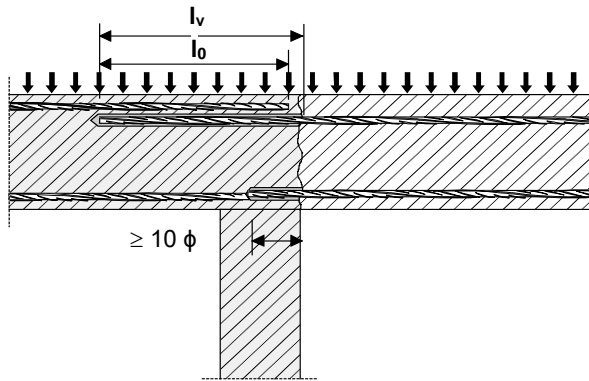

Figure 1.2 Overlap joint for rebar connections of slabs and beams

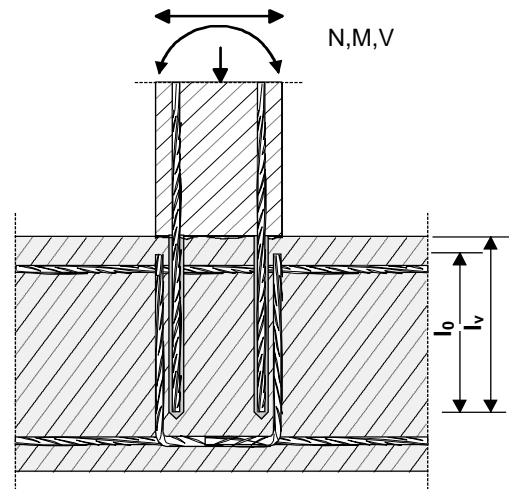

Figure 1.3 Overlap joint at a foundation of a column or wall where the rebar is stressed in tension

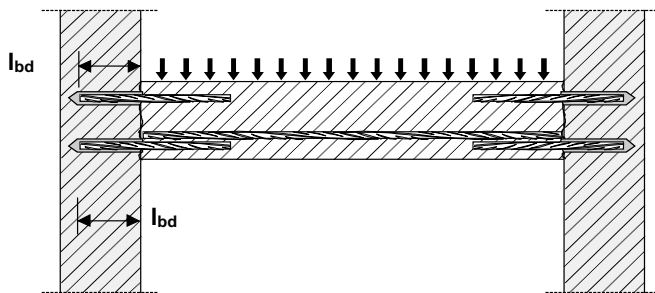

Figure 1.4 End anchoring of slabs or beams, designed as simply supported

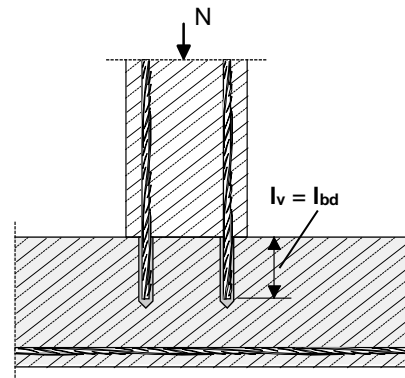
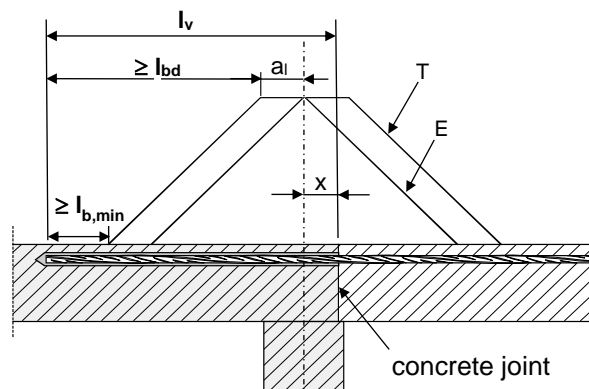

Figure 1.5 rebar connection for components stressed primarily in compression; rebar is stressed in compression



(only post-installed rebar is plotted)

Key to Figure 1.6

- T acting tensile force
- E envelope of $M_{ed}/Z + N_{ed}$ (see EN 1992-1-1 [1], Figure 9.2)
- x distance between the theoretical point of support and concrete joint

Note to Figure 1.2 to 1.6:

In the Figures no transverse reinforcement is plotted, the transverse reinforcement as required by EN 1992-1-1 [1] shall be present.

The shear transfer between old and new concrete shall be designed according to EN 1992-1-1 [1].

Figure 1.6 Anchoring of reinforcement to cover the line of acting tensile force

Examples for use of rebar tension anchor

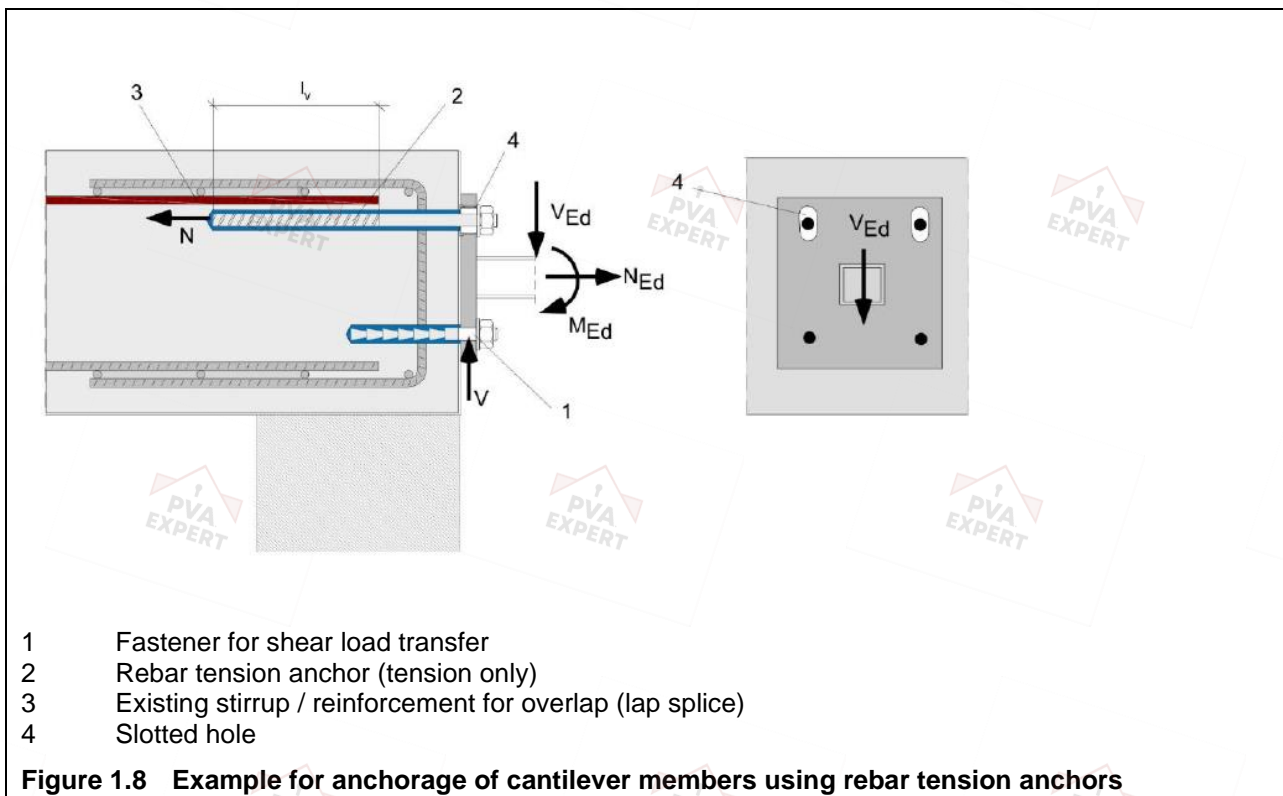
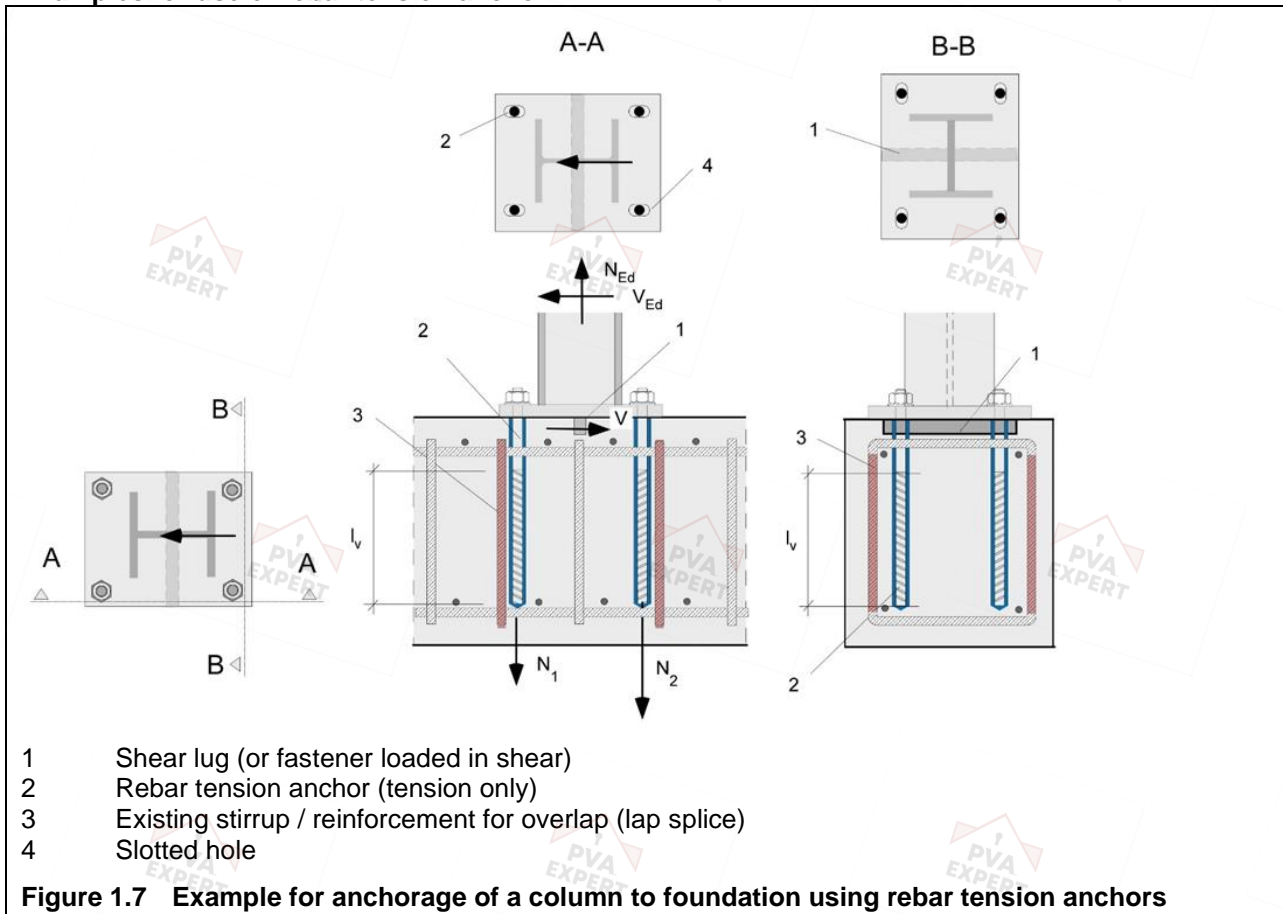

It is assumed that the product is installed in accordance with the manufacturer's product installation instructions (MPII).

The assessment methods of this EAD and the resulting performance characteristics are valid under the following conditions:

- Minimum concrete cover c_{min} as given in Table 1.1 and Table 1.2 are observed.
- Minimum clear spacing between two post-installed bars is $a = 40 \text{ mm} \geq 4 \phi$

Table 1.1 Minimum concrete cover c_{min}

Drilling method	Bar diameter ϕ	c_{min}
Hammer drilling or diamond drilling	< 25 mm	30 mm + 0,06 $l_v \geq 2 \phi$
	≥ 25 mm	40 mm + 0,06 $l_v \geq 2 \phi$
Compressed air drilling	< 25 mm	50 mm + 0,08 l_v
	≥ 25 mm	60 mm + 0,08 $l_v \geq 2 \phi$

The factors 0,06 and 0,08 in Table 1.1 take into account the possible deviations during the drilling process. These factors might be smaller if drilling aid devices (see Figure 1.9) are used. When using such a drilling aid device the minimum concrete cover may be reduced as given in Table 1.2.

Table 1.2 Minimum concrete cover c_{min} when using a drilling aid

Drilling method	Bar diameter ϕ	With drilling aid: c_{min}
Hammer drilling or diamond drilling	< 25 mm	30 mm + 0,02 $l_v \geq 2 \phi$
	≥ 25 mm	40 mm + 0,02 $l_v \geq 2 \phi$
Compressed air drilling	< 25 mm	50 mm + 0,02 l_v
	≥ 25 mm	60 mm + 0,02 $l_v \geq 2 \phi$

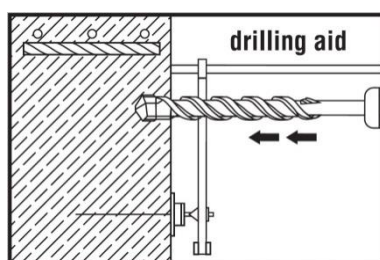

Figure 1.9 Example of drilling aid

1.2.2 Working life/Durability

The assessment methods included or referred to in this EAD have been written based on the manufacturer's request to consider a working life of the post-installed rebar connection for the intended use of 50 and/or 100 years when installed in the works (provided that the post-installed rebar connection is subject to appropriate installation (see 1.1)). These provisions are based upon the current state of the art and the available knowledge and experience.

When assessing the product, the intended use as foreseen by the manufacturer shall be considered. The real working life may be, in normal use conditions, considerably longer without major degradation affecting the basic requirements for works².

The indications given as to the working life of the construction product cannot be interpreted as a guarantee neither given by the product manufacturer or his representative nor by EOTA when drafting this EAD nor by the Technical Assessment Body issuing an ETA based on this EAD, but are regarded only as a means for expressing the expected economically reasonable working life of the product.

² The real working life of a product incorporated in a specific works depends on the environmental conditions to which that works is subject, as well as on the particular conditions of the design, execution, use and maintenance of that works. Therefore, it cannot be excluded that in certain cases the real working life of the product may also be shorter than referred to above.

1.3 Specific terms used in this EAD

1.3.1 Abbreviations

MPII	= manufacturer's product installation instructions
CI	= cast-in rebar
rqd	= required

1.3.2 Notation

a, b	= exponential fitting curve constants for equation (2.30), curve fitting parameter in equation (2.2)
a_l	= distance between the envelope of acting tensile force and moment curve (shift rule) according to EN 1992-1-1 [1] 6.2.2 (5) and 9.2.1.3 (2)
$c_{min,seis}$	= minimum concrete cover (seismic loading) see Table 2.6
CV_F	= coefficient of variation of failure loads
d_0	= nominal drill hole diameter
f_{bd}	= design value of the ultimate bond stress according to EN 1992-1-1 [1], 8.4.2
$f_{bd,PIR}$	= design value of the bond strength of a post-installed rebar
$f_{bd,PIR,seis}$	= design value of the bond strength of a post-installed rebar under seismic conditions to be used as f_{bd} for seismic action according to EN 1992-1-1 [1], 8.4.2
$f_{bd,fi}(\theta)$	= bond strength under fire exposure for 50 years working life
$f_{bd,fi,100y}(\theta)$	= bond strength under fire exposure for 100 years working life
f_{bm}	= mean value of ultimate bond strength for each concrete strength class
$f_{bm,cr,rqd}$	= required mean value of bond strength in cracked concrete (test series according to Table A.1, line 3)
$f_{bm,cr,t}$	= mean bond resistance in cracked concrete for the concrete strength class under consideration
$f_{bm,rqd}$	= required mean bond resistance for post installed rebar for assessment as equivalent to cast-in reinforcing bars (see Table A.4)
$f_{bm,rqd,d}$	= decisive required mean bond strength for specific concrete class equal to $f_{bm,rqd}$ for the assessment according to 2.2.2.1 a), but may be smaller than $f_{bm,rqd}$ for the assessment according to 2.2.2.1 b).
$f_{bm}(\theta)$	= mean bond resistance at the temperature θ
$f_{bm}(21^\circ\text{C})$	= mean bond strength at normal ambient temperature
$f_{bm,t,1}$	= mean bond resistance according to equation (A.2) resulting from tests according to Table A.1, line 1
$f_{bm,t,2}$	= mean bond resistance according to equation (A.2) resulting from tests according to Table A.1, line 2
$f_{bm,20};$ $f_{bm,50}$	= mean bond resistance for the post- installed rebar system in concrete C20/25 and C50/60, respectively

$f_{b,t}$	= bond stress in tests according to Table A.1, line 18
f_{ck}	= nominal cylinder strength of concrete according to EN 206 [3]
$f_{c,20}$	= characteristic concrete compressive strength for C20/25
$f_{c,50}$	= characteristic concrete compressive strength for C50/60
$f_{c,t}$	= concrete compressive cylinder strength of the test member
f_R	= relative rib area of tested rebar according to EN ISO 15630-1 [8]
f_{yk}	= characteristic tensile (yield) strength of reinforcement
h	= thickness of the concrete member
h_{sl}	= measured thickness of a slice in a test
k_{fi}	= temperature reduction factor
k_b	= bond efficiency factor for assumed working life of 50 years
$k_{b,100y}$	= bond efficiency factor for assumed working life of 100 years
$k_{b,fi}$	= temperature bond efficiency factor for assumed working life of 50 years
$k_{b,fi,100y}$	= temperature bond efficiency factor for assumed working life of 100 years
$k_{b,seis}$	= seismic bond efficiency factor
l_{bd}	= design anchorage length according to EN 1992-1-1 [1] 8.4.4
$l_{b,min}$	= minimum anchorage length according to EN 1992-1-1 [1] 8.4.4
l_o	= design lap length according to EN 1992-1-1 [1] 8.7.3
l_e	= embedment length of the (fully or partially) threaded bolt of a rebar tension anchor in the concrete (see to Figure 1.1)
$l_{e,ges}$	= overall embedment length in the concrete
l_v	= embedment length (bond length in seismic assessment, setting depth) of the post-installed rebar
m	= normalisation exponent taking into account the effect of concrete strength on bond
n	= number of tests in a test series
N_{sust}	= tension load applied during the sustained load test
N_{test}	= tension load applied in the test for resistance to fire
$N_{u,fc}$	= failure (peak) load in the test converted to nominal concrete strength
$N_{u,m}$	= mean value of failure load
$N_{u,t}$	= failure (peak) load in the tests
s	= Displacement
t	= Time
T	= temperature in tests according to Table A.1, line 14
α	= reduction factor representing the ratio between tested failure load and corresponding reference, see equation (A.6)

α_{lb}	= amplification factor for minimum anchorage length and splice length
α_p	= reduction factor according to A2.8 accounting for load reduction in sections 2.2.1.7, 2.2.1.8 and 2.2.1.9
β_{cv}	= reduction factor resulting from large coefficients of variation
Δw	= crack width for tests in cracked concrete
δ	= displacement in tension tests
δ_1	= limiting displacement
ϕ	= nominal diameter of the reinforcing bar
ϕ_{max}	= maximum diameter of rebar specified by the manufacturer of the post-installed rebar system
ϕ_{med}	= medium diameter of rebar specified by the manufacturer of the post-installed rebar system
ϕ_{min}	= minimum diameter of rebar specified by the manufacturer of the post-installed rebar system
τ_u	= bond resistance in durability tests (tests according to Table A.1, line 16)
$\tau_{um(sto)}$	= mean bond resistance of the mortar in the slices stored in alkaline fluid or in sulphurous atmosphere
$\tau_{um,r}$	= mean bond resistance of the comparison tests in slices stored under normal conditions
θ	= temperature in fire resistance tests (tests according to Table A.1, line 18)
θ_k	= temperature in fire resistance tests (tests according to Table A.1, line 18) up to which the mortar maintains the full capacity
θ_{max}	= maximum temperature in fire resistance tests, where the bond resistance of the mortar is lost

1.3.3 Indices

bd	= bond, design level
bm	= bond, mean value
c	= referencing specific concrete cylinder strength; the index c may be replaced by 20 for concrete strength class C20/25 or any other as chosen by the manufacturer.
CI	= cast-in rebar
cv	= coefficient of variation
env	= envelope of a load-displacement curve in a cyclic test, see section 2.2.5.3
F	= failure load
fi	= under fire exposure
i	= number of a cycle in a test
m	= mean value
max	= Maximum

min	=	Minimum
nom	=	Nominal
PIR	=	post-installed rebar
r	=	Reference
res	=	residual load test, performed after cyclic phase of a cyclic test, see section 2.2.5.3
reqd	=	Required
seis	=	under seismic loading
stat	=	under static loading
sust	=	sustained load
t	=	Test
u	=	Ultimate
0	=	initial value (e.g., initial displacement)
5%	=	5% fractile value
16	=	normalised to cylinder strength of concrete for C16/20
20	=	normalised to cylinder strength of concrete for C20/25
50	=	normalised to cylinder strength of concrete for C50/60
100y	=	working life of 100years
δ	=	Displacement

1.3.4 Definitions

mortar	=	bonding material that is part of the post-installed rebar system
normal ambient temperature	=	temperature in the concrete: 21 °C ± 3 °C
rebar	=	deformed reinforcing bar
Bond stress	=	Stress, caused by a force in the rebar, related to the nominal diameter of the rebar
Bond strength	=	Ultimate bond stress related to the nominal diameter of rebar (synonymous to bond resistance)

2 ESSENTIAL CHARACTERISTICS AND RELEVANT ASSESSMENT METHODS AND CRITERIA

2.1 Essential characteristics of the product

Table 2.1 shows how the performance of post-installed rebar connections with mortar is assessed in relation to the essential characteristics.

Table 2.1 Essential characteristics of the product and methods and criteria for assessing the performance of the product in relation to those essential characteristics

No	Essential characteristic	Assessment method	Type of expression of product performance
Basic Works Requirement 1: Mechanical resistance and stability			
Characteristic resistance under static and quasi-static loading			
1	Bond strength of post-installed rebar	2.2.1	Level $f_{bd,PIR}$ [N/mm ²], $f_{bd,PIR,100y}$ [N/mm ²]
2	Bond efficiency factor	2.2.2	Level k_b [-], $k_{b,100y}$ [-]
3	Amplification factor for minimum anchorage length	2.2.3	Level α_{lb} [-], $\alpha_{lb,100y}$ [-]
4	Characteristic resistance to steel failure for rebar tension anchors	2.2.6	Level $N_{Rk,s}$ [kN]
Characteristic resistance under seismic loading			
5	Bond strength under seismic loading, Seismic bond efficiency factor	2.2.4	Level $f_{bd,PIR,seis}$ [N/mm ²], $k_{b,seis}$ [-], $f_{bd,PIR,seis,100y}$ [N/mm ²], $k_{b,seis,100y}$ [-]
6	Minimum concrete cover under seismic loading	2.2.5	Level $c_{min,seis}$ [mm]
Basic Works Requirement 2: Safety in case of fire			
7	Reaction to fire	2.2.10	Class
Resistance to fire			
8	Bond strength at increased temperature for post-installed rebar assessed for 50 years	2.2.7	Level $f_{bd,fi}(\theta)$ [N/mm ²]; $k_{fi}(\theta)$ [-], θ_{max} [°C]
9	Bond strength at increased temperature for post-installed rebar assessed for 100 years	2.2.8	Level $f_{bd,fi,100y}(\theta)$ [N/mm ²]; $k_{fi,100y}(\theta)$ [-], θ_{max} [°C]
10	Characteristic resistance to steel failure for rebar tension anchors under fire exposure	2.2.9	Level $N_{Rk,s,fi}$ [kN]

2.2 Methods and criteria for assessing the performance of the product in relation to essential characteristics of the product

This chapter is intended to provide instructions for TABs. Therefore, the use of wordings such as “shall be stated in the ETA” or “it has to be given in the ETA” shall be understood only as such instructions for TABs on how results of assessments shall be presented in the ETA. Such wordings do not impose any obligations for the manufacturer and the TAB shall not carry out the assessment of the performance in relation to a given essential characteristic when the manufacturer does not wish to declare this performance in the Declaration of Performance.

An overview of the test program for the assessment of the various essential characteristics of the product is given in Annex A.

Provisions valid for all tests and general aspects of the assessment are also given in Annex A.

Details of tests are given in Annex B.

2.2.1 Bond strength of post-installed rebar

2.2.1.1 Reference tension tests in uncracked concrete (test series 1 and 2)

Purpose of the assessment

The test is needed to assess the bond strength of the post-installed reinforcing bar system with the mortar and to establish reference for the assessment of the test series Table A.1, line 7,8,12 to 15.

Assessment method

Test procedure

The tension tests shall be performed in uncracked concrete C20/25 (test series 1) with an embedment length of the bar of 10ϕ for all diameters ϕ and in uncracked concrete C50/60 (test series 2) with an embedment length of the bar of 7ϕ for the maximum rebar diameter ϕ_{max} . However, the embedment depth shall be reduced in case of steel failure mode. The reduction shall be the same in all test series.

The range of tested sizes ϕ may be reduced to s/m/l (noting that reference tests with $\phi = 12$ mm are required) if the installation system is consistent with respect to cleaning and injection effect (see Note 2). The reduced range depends on the number of sizes given in the ETA per request by the applicant and is given in Table A.2.

The number of sizes shall be distributed equally in the range of sizes between ϕ_{min} and ϕ_{max} .

Note 2 Check the difference of drill bit diameter to rebar diameter, difference of outer brush diameter to nominal drill bit diameter, same material, thickness and density of bristles of the specified brushes, same type of blowing/vacuuming (e.g., hand pump, compressed air tool), same type of dispensers (e.g., manual, electric, pneumatic).

The tests shall be performed with the same embedment length l_v as in tests for robustness in dry and wet concrete (Table A.1, line 7 and 8).

Assessment

Failure loads of tension tests:

- Determine the mean value of failure loads $N_{u,m}$ [kN] and the corresponding mean bond resistance f_{bm} in accordance with A2.5.
- Verify the coefficient of variation of failure loads. If the coefficient of variation exceeds 15% ($cv_F > 15\%$), determine the reduction factor for large scatter β_{cv} according to A2.7.

Load displacement behaviour:

- Determine the load at loss of adhesion $N_{u,adh}$ according to A2.10 and the corresponding displacement $s_{u,adh}$ at the load at loss of adhesion (reference value for test series 14).

2.2.1.2 Robustness in dry concrete (test series 7)

Purpose of the assessment

The test series is required to check the influence of reduced cleaning effort in dry concrete (equilibrium moisture content) on the bond strength. This test series may be omitted if no cleaning is specified in the MPII.

Assessment method

Test procedure

The test series may be omitted if the reduction for this aspect has been determined for a reinforcing bar in accordance with EAD 330499 [4]. The tension tests shall be performed in uncracked concrete C20/25 with an effective embedment length of the bar of 10ϕ and bar diameters in accordance with Table A.1, line 7.

To account for unfavourable cleaning conditions for larger embedment depths the installation of the rebar shall be carried out with an increased embedment depth as follows (see also A2):

Use a test member consisting of two concrete blocks A and B stacked on the top of each other without a permanent connection as shown in Figure A.1 a). Drill the hole in accordance with the procedures described in the MPII. Clean the hole as described below. Install the mortar in accordance with the MPII to the limited depth of the bottom block B (Figure A.1 b)) with the equipment supplied by the manufacturer. Remove the upper block A and install the rebar element (Figure A.1c)). After curing perform the tension test.

The following cleaning process of the hole has to be carried out in the tests.

Clean the hole with the equipment supplied by the manufacturer using two blowing operations by hand pump or compressed air and one brushing operation, i.e., either blow-brush-blow or blow-blow-brush or brush-blow-blow. The type of blowing and the order of brushing/blowing shall be done as prescribed in the MPII. This test procedure is valid only if the MPII specify hole cleaning with at least four blowing and two brushing operations, meaning twice the operations given above. If the instructions specify less than this, the above requirement (2 blows + 1 brush) shall be reduced proportionately and the number of blows/brushes shall be lowered to the next whole number. Therefore, where the MPII recommend two blowing and one brushing operations, the tests shall be carried out without the brushing operation and one blowing only.

If the MPII recommends a vacuum cleaning instead of a blowing operation, the same procedure (including requirements and corresponding reduced operations) applies. If the vacuum cleaning is part of the drilling process, the drilling shall be done without venting (meaning, airing out the dust by periodically moving the drill bit out of the hole) during the drilling process. If the cleaning is performed with suction bit or a hollow drill bit, then the vacuum with the smallest specified maximum flow rate shall be used during the drilling process.

If precise instructions for hole cleaning are not provided by the MPII, the tests are carried out without hole cleaning.

The tests shall be performed with the same embedment length l_v as in reference test series (Table A.1, line 1).

Assessment

Failure loads of tension tests:

- Determine the mean value of failure loads $N_{u,m}$ [kN] and the corresponding mean bond resistance f_{bm} in accordance with A2.5, converted to the nominal concrete strength.
- Verify the coefficient of variation of failure loads. If the coefficient of variation exceeds 20% ($CV_F > 20\%$), determine the reduction factor for large scatter β_{cv} according to A2.7.
- Determine the reduction factor α according to Annex A, section A2.9 comparing the test results with reference test series according to Table A.1, line 1.
- If $\alpha < 0,80$ use the reduction factor α together with r_{qd} . $\alpha = 0,80$ in equations (2.6) and (2.7).
- The smaller bond resistance and possible reduction in tests with sizes s/m/l shall also be applied to neighbouring intermediate diameter sizes untested.

2.2.1.3 Robustness in wet concrete (test series 8)

Purpose of the assessment

The test series is required to check the influence of reduced cleaning effort in water saturated concrete. Test series may be omitted if no cleaning is specified in the MPII for mortars based on cement only.

Assessment method

Test procedure

The test series may be omitted if the reduction for this aspect has been determined for a reinforcing bar in accordance with EAD 330499 [4]. The tension tests shall be performed in uncracked concrete C20/25 with an effective embedment length of the bar of 10ϕ and bar diameters in accordance with Table A.1, line 8.

Hole drilling and cleaning as well as installation of the mortar and rebar element shall be carried out according to 2.2.1.2. However, the concrete shall be water saturated when the hole is drilled, cleaned and the rebar is installed.

The following procedure may be applied to ensure a water saturated concrete in both concrete blocks A and B (see Figure A.1).

1. A hole with diameter approximately $0,5 \times d_0$ (d_0 = drill hole diameter of the tested rebar) is drilled in the concrete substrate to the required depth l_v (PIR) or $l_{e,ges}$ (rebar tension anchor).
2. The hole is filled with water and remains water-filled for 8 days until water has percolated into the concrete at a distance equal to $1,5 d_0$ to $2 d_0$ from the axis of the hole.
3. Water is removed from the hole.
4. The final hole is drilled with the recommended diameter d_0 to the required depth l_v (PIR) or $l_{e,ges}$ (rebar tension anchor).

If methods other than those described above are used it shall be shown by appropriate methods that the concrete in the area of the anchorage is water saturated.

Clean the hole with the equipment supplied by the manufacturer using two blowing operations by hand pump or compressed air and one brushing operation, i.e., either blow-brush-blow or blow-blow-brush or brush-blow-blow. The type of blowing and the order of brushing/blowing shall be done as prescribed in the MPII. This test procedure is valid only if the MPII specify hole cleaning with at least four blowing and two brushing operations, meaning twice the operations given above. If the instructions specify less than this, the above requirement (2 blows + 1 brush) shall be reduced proportionately and the number of blows/brushes shall be lowered to the next whole number. Therefore, where the MPII recommend two blowing and one brushing operation, the tests shall be carried out without the brushing operation and one blowing only.

If the MPII recommends a vacuum cleaning instead of a blowing operation, the same procedure (including requirements and corresponding reduced operations) applies. If the vacuum cleaning is part of the drilling process, the drilling shall be done without venting (meaning, airing out the dust by periodically moving the drill bit out of the hole) during the drilling process." If the cleaning is performed with suction bit or a hollow drill bit, then the vacuum with the smallest specified maximum flow rate shall be used during the drilling process.

If methods other than those described above are used it shall be shown by appropriate methods that the concrete in the area of the anchorage is water saturated.

The tests shall be performed with the same embedment length l_v as in reference test series (Table A.1, line 1).

Assessment

Failure loads of tension tests:

- Determine the mean value of failure loads $N_{u,m}$ [kN], and the corresponding mean bond resistance f_{bm} in accordance with A2.5 converted to the nominal concrete strength.
- Verify the coefficient of variation of failure loads. If the coefficient of variation exceeds 20% ($CV_F > 20\%$), determine the reduction factor for large scatter β_{cv} according to A2.7.
- Determine the reduction factor α according to Annex A, section A2.9 comparing the test results with reference test series according to Table A.1, line 1.

- If $\alpha < 0,75$, use the reduction factor α together with reqd. $\alpha = 0,75$ in equation (2.6) and (2.7).

The smaller bond resistance and possible reduction in tests with sizes s/m/l shall also be applied to neighbouring intermediate diameter sizes untested.

2.2.1.4 Installation at minimum and maximum installation temperature (test series 9, 10)

Purpose of the assessment

The test series are required to check if the rebar can be installed properly at maximum embedment depth before curing of the mortar.

The test series 9 may be omitted for minimum installation temperature $> 0^{\circ}\text{C}$ and minimum mortar temperature $\geq 5^{\circ}\text{C}$.

Assessment method

Test procedure

In the test it is checked whether a rebar with the maximum embedment depth can be installed correctly with the installation tools defined in the MPII (including drilling, cleaning, injection of the mortar and installation of the rebar). The tests are done with the maximum rebar diameter and the maximum embedment depth applied for. If during installation significant splitting forces are created, tests shall be done with minimum concrete cover. The temperature of the concrete, rebar and mortar shall comply with the installation conditions specified by the manufacturer at minimum (Table A.1, line 9) and maximum (Table A.1, line 10) specified installation temperature. The rebar is installed according to the MPII. The tests shall be done for each installation system (e.g., manual/electric/pneumatic dispensers) specified by the manufacturer.

Assessment

It shall be possible to install the rebar properly (required embedment depth is reached and the mortar comes out of the hole). Otherwise, the test shall be repeated with modified minimum or maximum installation temperature or maximum embedment depth or maximum diameter size until the condition is fulfilled.

2.2.1.5 Correct injection (test series 11)

Purpose of the assessment

In the test it is checked if the injection of the mortar can be done properly without voids.

Assessment method

Test procedure

The injection tests are performed at the lowest installation temperature (of rebar, acryl tube and temperature of the test chamber and minimum storage temperature of the injection mortar) in acryl tubes with an inner diameter equal to or 1 mm less than the drilling diameter. The tests are done in horizontal direction with the maximum rebar diameter and the maximum embedment depth applied for. During the injection of the mortar the acryl tube shall be covered so that the installer cannot see the flow of the injection mortar. After the injection insert the bar to the required depth.

Note 3 Acryl tubes are available with an inner diameter from 2 to 250 mm in steps of 2 mm; e.g., for drilling diameter $d_0 = 25$ mm an acryl tube of 24 mm is recommended

Assessment

The mortar shall fill completely the gap between rebar and hole of the acryl tube over the entire embedment depth. Small voids are usually unavoidable. However, the size and number of these voids shall be such that they do not adversely affect the bond strength of the mortar and the corrosion resistance. Sagging of the rebar in the fresh mortar immediately after placing and adjustment shall be checked. Significant sagging must not occur.

2.2.1.6 Installation direction (test series 12, 13)

Purpose of the assessment

The tests are performed to check the performance under unfavourable installation directions. The test series may be omitted for downward installation only (D1).

Assessment method**Test procedure**

If the manufacturer allows in the MPII all installation directions (D3) or does not specify any specific installation direction, tension tests are needed vertically upwards because this is the most critical installation direction if dropping of mortar reduces the performance. If the manufacturer allows horizontal and vertical downward only (D2), tension tests have to be done installed in horizontal direction because this is the most critical installation direction. Special devices to maintain the fastener in place are used only if stated in the MPII. Such special devices shall also be described in the ETA.

Perform the tests with confined test setup. The tests are performed in uncracked low strength concrete C20/25 with largest diameter size applied for by the manufacturer. The tension tests are performed according to Annex B.

The reference test series (Table A.1, line 1) shall be performed with the same embedment length l_v .

AssessmentFailure loads of tension tests:

- Determine the mean value of failure loads $N_{u,m}$ [kN] and the corresponding mean bond resistance f_{bm} in accordance with A2.5, converted to the nominal concrete strength.
- Verify the coefficient of variation of failure loads. If the coefficient of variation exceeds 20% ($CV_F > 20\%$), determine the reduction factor for large scatter β_{cv} according to A2.7.
- Determine the reduction factor α according to Annex A, section A2.9 comparing the test results with reference test series according to Table A.1, line 1.
- If $\alpha < 0,90$, use the reduction factor α together with r_{qd} . $\alpha = 0,90$ in equations (2.6) and (2.7).

2.2.1.7 Sustained loads (test series 14)Purpose of the assessment

The tests are performed to check the creep behaviour of the loaded rebar at normal ambient temperature and at maximum long-term temperature.

Assessment method**Test procedure****a) 50 years working life**

The test series may be omitted if the reduction for this aspect is taken from assessment according to EAD 330499 [4] for threaded rods. In this case any reduction factor gained with threaded rods shall be applied also for rebar.

The tests shall be carried out as confined tests in uncracked concrete C20/25, both at normal ambient concrete temperature and maximum long-term concrete temperature as specified by the manufacturer (see 1.2.1). The permanent stress N_{sust} can be applied by a hydraulic jack, by springs or by dead loads, e.g., applied via a lever arm.

If more than one drilling diameter is given in the MPII for the same rebar diameter, drilling shall be done with the largest drilling diameter.

Install rebar at normal ambient temperature. Apply the load N_{sust} in accordance with (2.1).

$$N_{sust} = 0,55 \cdot f_{bm,t,1} \cdot \pi \cdot \phi \cdot l_v \cdot \left(\frac{f_{c,t}}{f_{c,20}} \right)^n \quad (2.1)$$

with $f_{bm,t,1} \leq 10,0 \text{ N/mm}^2$

For range T1 maintain load at N_{sust} and maintain temperature at normal ambient temperature ($T = 21 \text{ }^\circ\text{C}$) and measure the displacements until they appear to have stabilized, but at least for three months.

For range T2 or T3 maintain load at N_{sust} after curing and raise the temperature of the test chamber to maximum long-term temperature at a rate of approximately 20 K per hour or at 5 K in the concrete in the

area of the rebar. Maintain load at N_{sust} and maintain temperature and measure the displacements until they appear to have stabilized, but at least for three months. Temperatures in the room may vary by ± 3 °C due to day/night and seasonal effects but the required test room temperature level shall be achieved as a mean over the test period.

The frequency of monitoring displacements shall be chosen so as to demonstrate the characteristics of the rebar. As displacements are greatest in the early stages, the frequency shall be high initially and reduced with time.

The following regime shall be kept as a minimum:

During first hour:	every 10 minutes
During next 6 hours:	every hour
During next 10 days:	every day
From then on:	every 5-10 days.

The stabilization of displacements has to be checked as defined by the following steps:

1. The displacement data have to be viewed in a plot with the logarithm of the time of sustained loading on the x-axis and the logarithm of the displacement on the y-axis.
2. The data plotted as described in step 1 shall show concave-down or approximately linear behaviour.
3. If step 2 is not satisfied, continue to apply the sustained load until this criterion is met.

If the displacements are not stabilized the tests shall be repeated with a reduced load $N_{\text{sust,red}}$.

To check the remaining load capacity after the sustained load test, unload the rebar and carry out a confined tension test at maximum long-term temperature.

The results of the residual load capacity test shall be compared with the load capacity of reference test series according to Table A.1, line 1. The reference test series shall be performed with the same embedment length l_v .

b) 100 years working life

The tests shall be carried out as confined tests in uncracked concrete C20/25, both at normal ambient concrete temperature and maximum long-term concrete temperature as specified by the manufacturer (see 1.2.1). The permanent stress N_{sust} can be applied by a hydraulic jack, by springs or by dead loads, e.g., applied via a lever arm.

If more than one drilling diameter is given in the MPII for the same rebar diameter, drilling shall be done with the largest drilling diameter.

Install rebar at normal ambient temperature. Apply the load N_{sust} in accordance with equation (2.1).

For range T1 maintain load at N_{sust} (the applied load shall not decrease to less than N_{sust} and shall vary by no more than 5% from the initially applied load) and maintain temperature at normal ambient temperature ($T = 21$ °C) and measure the displacements until they appear to have stabilized, but at least for six months.

For range T2 or T3 maintain load at N_{sust} after curing and raise the temperature of the test chamber to maximum long-term temperature at a rate of approximately 20 K per hour or at 5 K in the concrete in the area of the rebar. Maintain load at N_{sust} (the applied load shall not decrease to less than N_{sust} and shall vary by no more than 5% from the initially applied load) and maintain temperature and measure the displacements until they appear to have stabilized, but at least for six months. Temperatures in the room may vary by ± 3 °C due to day/night and seasonal effects but the required test room temperature level shall be achieved as a mean over the test period.

The frequency of monitoring displacements shall be chosen so as to demonstrate the characteristics of the rebar. As increase of displacements is greatest in the early stages, the frequency shall be high initially and reduced with time.

The following regime shall be kept as a minimum:

During first hour: every 10 minutes
 During next 6 hours: every hour
 From then on: every day

The stabilization of displacements has to be checked as defined by the following steps:

1. At least the final three months of displacement data have to be viewed in a plot with the logarithm of the time of sustained loading on the x-axis and the logarithm of the displacement on the y-axis.
2. The data plotted as described in step 1 shall show concave-down or approximately linear behaviour.
3. If step 2 is not satisfied, continue to apply the sustained load until this criterion is met.

If the displacements are not stabilized the tests shall be repeated with a reduced load $N_{\text{sust,red}}$.

To check the remaining load capacity after the sustained load test, unload the rebar and carry out a confined tension test at maximum long-term temperature.

The results of the residual load capacity test shall be compared with the load capacity of reference test series according to Table A.1, line 1. The reference test series shall be performed with the same embedment length l_v .

If the product has previously been tested for 50 years working life with a sample size $n \geq 5$, n_{min} may be reduced to 3 provided that the following conditions are true for the assessment for 50 years.

1. A coefficient of variation $cv_F \leq 10\%$ has been achieved for ultimate loads in both reference tests and residual load tests;
2. The creep displacements in all of the sustained load tests shall show a clear stabilizing behaviour with the coefficient of variation of the displacements at the end of testing and the estimated displacements for 50 years (ambient temperature) and 10 years (maximum long-term temperature) applying the Findley approach shall not have exceeded 10% ($cv_\delta \leq 10\%$).

Assessment

a) 50 years working life

The displacements measured in the tests have to be extrapolated according to equation (2.2) (Findley approach) to 50 years (tests at normal ambient concrete temperature), or 10 years (tests at maximum long-term concrete temperature), respectively. The trend line according to equation (2.2) may be constructed with data from not less than the last 20 days and not less than 20 data points of the sustained load test. The extrapolated displacements shall be less than the mean value of the displacements $s_{u,adh}$ in the corresponding reference tests at normal ambient concrete temperature or maximum long-term concrete temperature respectively, $s_{u,adh}$ is the displacement at $N_{u,adh}$ (load at loss of adhesion, see A2.10) at normal ambient concrete temperature or maximum long-term concrete temperature respectively.

$$s(t) = s_0 + a \cdot t^b \quad (2.2)$$

If the extrapolated displacements do not meet the criteria, the test series shall be repeated with a reduced load N_{sust} . The applied sustained load in the test shall be assessed according to A2.8.

The result of the residual capacity tension tests at normal temperature as well as at maximum long-term concrete temperature shall both be compared with the reference series according to Table A.1, line 1 (performed at normal ambient concrete temperature).

- Determine the mean value of the failure loads $N_{u,m}$ and the corresponding mean bond resistance f_{bm} in accordance with A2.5.
- Determine the reduction factor α according to Annex A, section A2.9 comparing the test results with reference test series according to Table A.1, line 1.
- If $\alpha < 0,90$, use the reduction factor α together with rqd . $\alpha = 0,90$ in equations (2.6) and (2.7).
- Determine the reduction factor α_p according to section A2.8 and use the reduction factor α_p together with rqd . $\alpha = 0,90$ in equations (2.6) and (2.7).

b) 100 years working life

The displacements measured in the tests for a working life of 100 years have to be extrapolated according to equation (2.2) (Findley approach) to 100 years in tests at normal ambient temperature), or 20 years (tests at maximum long-term concrete temperature), respectively. The trend line according to equation (2.2) shall

be constructed with data from not less than the last 70 days of the sustained load test. The extrapolated displacements shall be less than the mean value of the displacements $s_{u,adh}$ in the corresponding reference tests at normal ambient concrete temperature or maximum long-term concrete temperature respectively. $s_{u,adh}$ is the displacement at $N_{u,adh}$ (load at loss of adhesion, see A2.10) at normal ambient concrete temperature or maximum long-term concrete temperature respectively.

$$s(t) = s_0 + a \cdot t^b \quad (2.2)$$

If the extrapolated displacements do not meet the criteria, the test series shall be repeated with a reduced load N_{sust} . The applied sustained load in the test shall be assessed according to Annex A, section A2.8.

The result of the residual capacity tension tests at normal temperature as well as at maximum long-term concrete temperature shall both be compared with the reference series according to Table A.1, line 1 (performed at normal ambient concrete temperature).

- Determine the mean value of the failure loads $N_{u,m}$ and the corresponding mean bond resistance f_{bm} in accordance with A2.5.
- Determine the reduction factor α according to Annex A, section A2.9 comparing the test results with reference test series according to Table A.1, line 1.
- If $\alpha < 0,90$, use the reduction factor α together with rqd. $\alpha = 0,90$ in equations (2.6) and (2.7).
- Determine the reduction factor α_p according to section A2.8 and use the reduction factor α_p together with rqd. $\alpha = 0,90$ in equations (2.6) and (2.7).

2.2.1.8 Freeze/thaw conditions (test series 15)

Purpose of the assessment

These tests are performed to determine the performance of the rebar under freeze/thaw conditions simulating service loads that are subject to variation over time.

Assessment method

Test procedure

The test series may be omitted if the reduction for this aspect and diameter is taken from assessment according to EAD 330499 [4]. Perform the tests with confined test setup. The tests are performed in uncracked freeze-thaw resistant concrete C50/60 in accordance with EN 206 [3]. As test member a cube with side length of 200 mm to 300 mm or $15 d_0$ to $25 d_0$ or a steel encased concrete cylinder shall be used and splitting of concrete shall be prevented.

Cover the top surface of the test member with tap water to a depth of 12 mm, other exposed surfaces shall be sealed to prevent evaporation of water.

The sustained load N_{sust} for the tests shall be determined according to equation (2.3).

$$N_{sust} = 0,4 \cdot f_{bm,t,2} \cdot \pi \cdot \phi \cdot l_v \cdot \left(\frac{f_{c,t}}{f_{c,50}} \right)^n \quad (2.3)$$

$$\text{with } f_{bm,t,2} \leq 18,4 \text{ N/mm}^2$$

Carry out 50 freeze/thaw cycles as follows:

- Raise temperature of chamber to $(+20 \pm 2)$ °C within 1 hour, maintain chamber temperature at $(+20 \pm 2)$ °C for 7 hours.
- Lower temperature of chamber to (-20 ± 2) °C within 2 hours, maintain chamber temperature at (-20 ± 2) °C for 14 hours (total of 16 hours).

If the test is interrupted, the samples shall always be stored at a temperature of $(+ 20 \pm 2)$ °C between the cycles.

The displacements shall be measured during the temperature cycles.

After completion of 50 cycles a confined tension test (residual load capacity test) shall be carried out at normal ambient concrete temperature.

a) Assessment (50 years working life)

The increase of displacements shall be stabilized with increasing number of freeze/thaw cycles to a value almost equal to zero.

If the extrapolated displacements do not meet the criteria, the test series shall be repeated with a reduced load N_{sust} .

The results of the residual load capacity test shall be assessed as follows:

- Determine the mean value of the failure loads $N_{u,m}$ and the corresponding mean bond resistance f_{bm} in accordance with A2.5.
- Determine the reduction factor α according to Annex A, section A2.9 comparing the test results with the reference tension test series at normal ambient concrete temperature with the same curing time.
- If $\alpha < 0,90$, use the reduction factor α together with r_{qd} . $\alpha = 0,90$ in equation (2.6) and (2.7).
- Determine the reduction factor α_p according to section A2.8 and use the reduction factor α_p together with r_{qd} . $\alpha = 0,90$ in equations (2.6) and (2.7).

b) Assessment (100 years working life)

The increase of displacements shall be stabilized with increasing number of freeze/thaw cycles to a value almost equal to zero.

If the extrapolated displacements do not meet the criteria, the test series shall be repeated with a reduced load N_{sust} . The applied sustained load in the test shall be assessed according to Annex A, section A2.8.

The results of the residual load capacity test shall be assessed as follows:

- Determine the mean value of the failure loads $N_{u,m}$ and the corresponding mean bond resistance f_{bm} in accordance with A2.5.
- Determine the reduction factor α according to Annex A, section A2.9 comparing the test results with the reference tension test series at normal ambient concrete temperature with the same curing time.
- If $\alpha < 0,95$, use the reduction factor α together with r_{qd} . $\alpha = 0,95$ in equation (2.6) and (2.7).
- Determine the reduction factor α_p according to section A2.8 and use the reduction factor α_p together with r_{qd} . $\alpha = 0,90$ in equations (2.6) and (2.7).

2.2.1.9 High alkalinity and sulphurous atmosphere (test series 16)***Purpose of the assessment***

These tests are performed to determine the performance of the rebar under sulphurous atmosphere and high alkalinity. This test series may be performed with threaded rods of size M12. High alkalinity tests are not required for mortars based on cement only. The test series may be omitted if the reduction for this aspect is taken from assessment according to EAD 330499 [4].

Test specimen:

The concrete compressive strength class shall be C20/25. The diameter or side length of the concrete specimen shall be equal to or exceed 150 mm. The test specimen may be manufactured from cubes or cylinders or may be cut from a larger slab. They can be cast. It is also allowed to diamond core concrete cylinders from slabs.

One steel element (medium size $\phi = 12$ mm or M12 or smallest size if the smallest size is larger than 12 mm) shall be installed per cylinder or cube on the central axis in dry concrete according to the MPII. The embedded part shall be made out of stainless steel.

After curing of the bonding material according to MPII the concrete cylinders or cubes are carefully sawn into 30 mm thick slices with a diamond saw. The top slice shall be discarded.

To gain sufficient information from the slice tests, at least 30 slices are necessary (10 slices for every environmental exposure test and 10 slices for the comparison tests under normal climate conditions).

Storage of the test specimen under environmental exposure:

The slices with bonded rebars are stored in water with high alkalinity and condensed water with sulphurous atmosphere. For comparison tests slices stored under normal climate conditions (dry / $+21$ °C \pm 3 °C / relative humidity 50 \pm 5%) for 2000 hours are necessary.

High Alkalinity:

The slices are stored under standard climate conditions in a container filled with an alkaline fluid (pH = 13.2). All slices shall be completely covered for 2.000 hours. The alkaline fluid is produced by mixing water with KOH (potassium hydroxide) powder or tablets until the pH-value of 13.2 is reached. The alkalinity of pH = 13.2 shall be kept as close as possible to 13.2 during the storage and not fall below a value of 13.0. Therefore, the pH-value has to be checked and monitored in regular intervals (at least daily). The producing of alkaline fluid by mixing water with KOH (potassium hydroxide) powder or tablets could be given as an example. If other materials are used, it has to be shown that same results and comparable assessment are achieved.

Sulphurous atmosphere:

The tests in sulphurous atmosphere shall be performed according to EN ISO 6988 [7]. The slices are put into the test chamber, however in contrast to EN ISO 6988 [7] the theoretical sulphur dioxide (SO₂) concentration shall be 0,67 % at beginning of a cycle. This theoretical sulphur dioxide concentration corresponds to 2 dm³ of SO₂ for a test chamber volume of 300 dm³. At least 80 cycles shall be carried out.

Slice tests

After the storage time, the thickness of the slices is measured and the metal segments of the bonded rebars are pushed out of the slice, the slice is placed centrally to the hole of the steel rig plate. If slices are unreinforced then splitting may be prevented by confinement. Care shall be taken to ensure that the loading punch acts centrally on the rebar rod.

The results of at least 10 tests shall be taken for every environmental exposure and for comparison. Results with splitting failure shall be ignored.

Assessment

Calculate the factor α_4 according to equation (2.4).

$$\alpha_4 = \min\left(\frac{\tau_{um,alkali}}{\tau_{um,r}}; \frac{\tau_{um,sulphur}}{0,9\tau_{um,r}}\right) \leq 1,0 \quad (2.4)$$

The reference bond strength $\tau_{um,r}$ is gained in the reference test series with unexposed slices.

The bond strength in the slice tests shall be calculated according to equation (2.5).

$$\tau_u = \frac{N_u}{\pi \cdot \phi \cdot h_{sl}} \quad (2.5)$$

2.2.1.10 Corrosion resistance of rebar (test series 17)Purpose of the assessment

Cast-in place rebars situated in non-carbonated concrete with limited chloride content according to EN 206 [3] are protected by the alkalinity of the concrete, which develops a passive layer on the steel surface during the hardening process of the concrete, along with the concrete cover.

No proof of the corrosion resistance of the rebar is needed if it is used in building components in dry surroundings according to exposure class X0 and XC1 of EN 1992-1-1 [1]. Also, no proof is needed when only corrosion resistant rebars are specified for all applications.

In all other cases it has to be shown by the following tests that post-installed rebar connections provide the same corrosion resistance as cast-in-place rebar.

Assessment method**Test procedure**

The principle test set-up is shown in Figure 2.1.

The test member is made of uncracked concrete C20/25. The mixture and storage is done as described in Annex B, B1.1 with the following modifications:

- the water/cement ratio shall be $\leq 0,6$ (covering all exposure classes given in EN 206 [3], Table F.1 for which the test is required)
- chlorides are added to the mix so that the chloride content of the concrete (expressed as mass proportion of chloride ions in cement) is 0,20 % or 0,40 % according to the class of chloride content according to EN 206 [3], Table 15.

The dimensions are either cubes of 150 mm x 150 mm x 150 mm or prism with a cross section of 150 x 150 mm and an arbitrary length. The age of the concrete cube at installation of the rebar shall be at least 21 days. Carbonated surfaces are to be removed. In minimum 3 rebars with the nominal diameter of 12 mm are to be used. They shall be cleaned in such a manner as to ensure no contamination of the rebar with other materials. A suitable method is to degrease with ethanol. They shall be ensured to be free from mill scale and other loose contaminants by cleaning methods recommended by the rebar manufacturer.

The installation of the rebar into the concrete is done according to the MPII for this size. The embedment depth is 70 mm (± 3 mm) and the edge distance is 75 mm. In case of prism the spacing between the rebars is at least 50 mm. The rebar is positioned so as to rest on the bottom of the drilled hole. The top side of the concrete member in the area of the post installed rebar is covered by epoxy resin to prevent carbonation.

After curing of the mortar, the concrete member is immersed into a container filled with artificial tap water (200 mg sodium sulphate and 200 mg sodium bicarbonate dissolved in 1 litre distilled water) (see Figure 2.1). By means of distance holder made of plastic, the concrete member is kept at least 1 cm above the bottom of the container. The water level shall be 10 mm above the bottom side of the installed rebar. For a height of the concrete member of 150 mm the water line shall, therefore, be 90 mm above the bottom side of the concrete member.

Each rebar is connected to a cathode with a 100 Ω resistor (accuracy class $\pm 1\%$). The cathodes are L-shaped and made of stainless steel (EN 10088-1 [5] and EN 10088-3 [6]: 1.4404, 1.4435 or 1.4539). They are positioned directly on the bottom of the container. The surface of the cathodes in contact to the water is at least 100 cm².

Previous to the test, the cathodes are degreased with ethanol, cleaned by exposing for 10 min in 5% Nitric acid and subsequent rinsing with distilled water. The cathodes have to be stored in the artificial tap water for at least 2 weeks, prior to run the test.

The current between the rebar and the cathode is readily determined by measuring the potential drop over the resistor with a micro voltmeter (e.g., using the device Keithley M2001) with a resolution of 100 nV and an input resistance of at least 10 M Ω .

The corrosion potential of each rebar is measured by a Voltmeter with an input resistance of at least 10 M Ω and a resolution of 0,1 mV (e.g., Keithley M2001) against a reference electrode (e.g., an AgCl coated silver wire immersed in a container filled with a dilute chloride solution (200 mg sodium sulphate, 200 mg sodium bicarbonate and 58 mg sodium chloride dissolved in one litre distilled water) and an opening closed by a diaphragm can be used).

An electrolyte bridge can be used to prevent significant pollution of the electrolyte with copper ions or chlorides. Every week the constancy of potential of the reference electrode has to be controlled with a saturated Cu/CuSO₄ electrode (CSE). The measurement of the potential shall be done continuously with intervals not greater than 1 hour.

The duration of the tests shall be at least 3 months. The measured current flow and the potential are plotted against the duration.

The reference test series shall be performed with the same embedment length l_v .

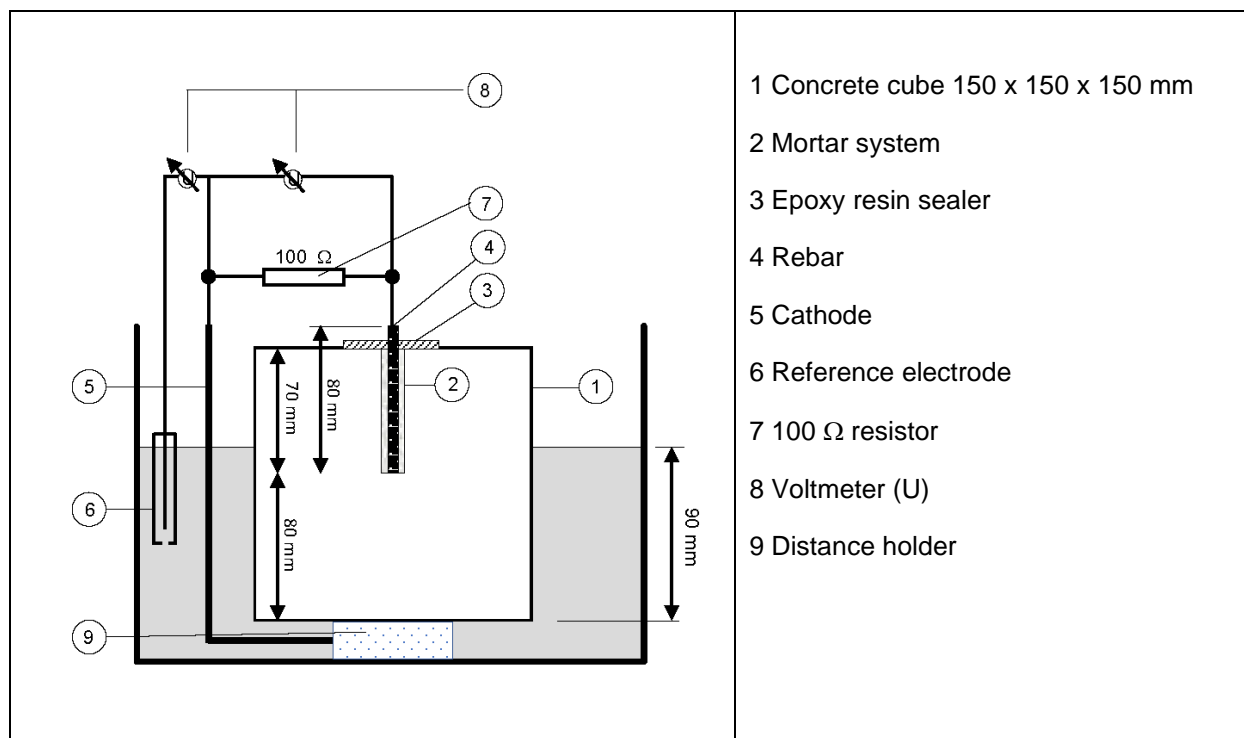

Figure 2.1 Example of test setup in concrete cubes

Assessment

In earlier basic research the daily mean value of the current with cast-in rebar was determined 0,28 μA and the potential $-0,2\text{V}$ CSE. These limits may be used for comparison with cast-in rebar as a reference to avoid parallel reference testing the corrosion resistance of cast-in rebar.

- During the last third of the testing period the daily mean value of the current shall not exceed 0,28 μA and the potential shall not be below $-0,2\text{V}$ CSE for all test samples.
- The potential criterion may be omitted if the current criterion of 0,28 μA is fulfilled for all samples and the visual inspection of the rebar after the test does not show any corrosion products.

If either condition (a) or (b) is fulfilled the corrosion resistance of the post-installed rebar connection can be judged as being comparable with the corrosion resistance of cast-in-place rebar.

2.2.1.11 Determination of bond strength for 50 years working life

Purpose of the assessment

Determination of bond strength for 50 years working life

Assessment method

The bond resistance for the assessment of the post-installed rebar shall be determined according to equations (2.6) and (2.7). Use $f_{bm,t,1}$ and $f_{bm,t,2}$ as determined in test series 1 and 2 of Table A.1.

$$C20/25: f_{bm,20} = f_{bm,t,1} \cdot \alpha_4 \cdot \min \beta_{cv} \cdot \min \left(\min \alpha_p; \min \frac{\alpha}{rqd \cdot \alpha} \right) \quad (2.6)$$

$$C50/60: f_{bm,50} = f_{bm,t,2} \cdot \alpha_4 \cdot \min \beta_{cv} \cdot \min \left(\min \alpha_p; \min \frac{\alpha}{rqd \cdot \alpha} \right) \quad (2.7)$$

where

$\min \beta_{cv}$ \leq 1,0; minimum value of the tests Table A.1, lines 1, 2, 7, 8, 12 and 13

$\min \alpha_p$ \leq 1,0; minimum value as determined from tests for 100 years working life in 2.2.1.7a) and 2.2.1.8a)

α_4 = as determined according to 2.2.1.9

$$\begin{aligned} \min \beta_{cv} &\leq 1,0; \text{ minimum value of tests Table A.1, lines 1, 2, 7, 8, 12 and 13} \\ \min \frac{\alpha}{rqd. \alpha} &\leq 1,0; \text{ minimum ratio of the tests Table A.1, line 7, 8, 12 to 15} \end{aligned}$$

Calculate the reduction factor k_b and the bond strength of post-installed rebar $f_{bd,PIR}$ in accordance with 2.2.2.1.

Expression of results

Bond strength of post-installed rebar $f_{bd,PIR}$ [N/mm²]

2.2.1.12 Determination of bond strength for 100 years working life

Purpose of the assessment

Determination of bond strength for 100 years working life

Assessment method

The bond resistance for the assessment of the post-installed rebar shall be determined according to equations (2.8) and (2.9). Use $f_{bm,t,1}$ and $f_{bm,t,2}$ as determined in test series 1 and 2 of Table A.1.

$$C20/25: f_{bm,20,100y} = f_{bm,t,1} \cdot \alpha_4 \cdot \min \beta_{cv} \cdot \min \left(\min \alpha_p; \min \frac{\alpha}{rqd. \alpha} \right) \quad (2.8)$$

$$C50/60: f_{bm,50,100y} = f_{bm,t,2} \cdot \alpha_4 \cdot \min \beta_{cv} \cdot \min \left(\min \alpha_p; \min \frac{\alpha}{rqd. \alpha} \right) \quad (2.9)$$

where

$$\min \frac{\alpha}{rqd. \alpha} = \leq 1,0; \text{ minimum ratio of the tests according to Table A.1, lines 7, 8, 12, 13 and test series 14 and 15 as determined in 2.2.1.7 b) and 2.2.1.8 b)}$$

$$\min \alpha_p = \leq 1,0; \text{ minimum value as determined from tests for 100 years working life in 2.2.1.7b) and 2.2.1.8b)}$$

$$\alpha_4 = \text{ as determined according to 2.2.1.9}$$

$$\min \beta_{cv} = \leq 1,0; \text{ minimum value of tests Table A.1, lines 1, 2, 7, 8, 12 and 13}$$

Calculate the reduction factor $k_{b,100y}$ and the bond strength of post-installed rebar $f_{bd,PIR,100y}$ in accordance with 2.2.2.2.

Expression of results

Bond strength of post-installed rebar $f_{bd,PIR,100y}$ [N/mm²]

2.2.2 Bond efficiency factor

2.2.2.1 50 years working life: factor k_b

Purpose of the assessment

The design value of the ultimate bond stress (design bond resistance) f_{bd} for ribbed bars (rebars) according to EN 1992-1-1 [1] depends on several National Determined Parameters.

The objective of this clause is to establish corrective coefficient k_b , representing influence of the product on limit bond stress f_{bd} calculated according to EN 1992-1-1 [1], 8.4.2.

Assessment method

The following assessment shall be made at least for the lowest mean bond strength $f_{bm,t,1}$ obtained from the range of the tested rebar diameters in the test series according to Table A.1, line 1. The results may be applied to all other sizes with higher mean bond strength.

The factor k_b for each concrete class shall be determined as given in equation (2.10) and rounded to the nearest hundredth.

$$k_b = \frac{f_{bm,rqd,d}}{f_{bm,rqd}} \leq 1,0 \quad (2.10)$$

Case a) No correction of limit bond stress f_{bd} according to EN 1992-1-1 [1] for all concrete strength classes

If the mean bond resistance $f_{bm,20}$ determined according to equation (2.6) and the mean bond resistance $f_{bm,50}$ determined according to equation (2.7) reaches at least the required bond resistance $f_{bm,rqd}$ (i.e., 10,0 N/mm² for C20/25 and 18,4 N/mm² for C50/60), the post-installed rebar may be designed using the design values of the ultimate bond stress, f_{bd} for ribbed bars according to EN 1992-1-1 [1] for the corresponding concrete strength class. In this case the decisive required bond strength $f_{bm,rqd,d}$ is equal to the required bond resistance $f_{bm,rqd}$, as given in Table A.4 for all concrete strength classes and hence, the factor $k_b = 1$ for all concrete strength classes. An example is shown in Figure 2.2 and Table 2.2.

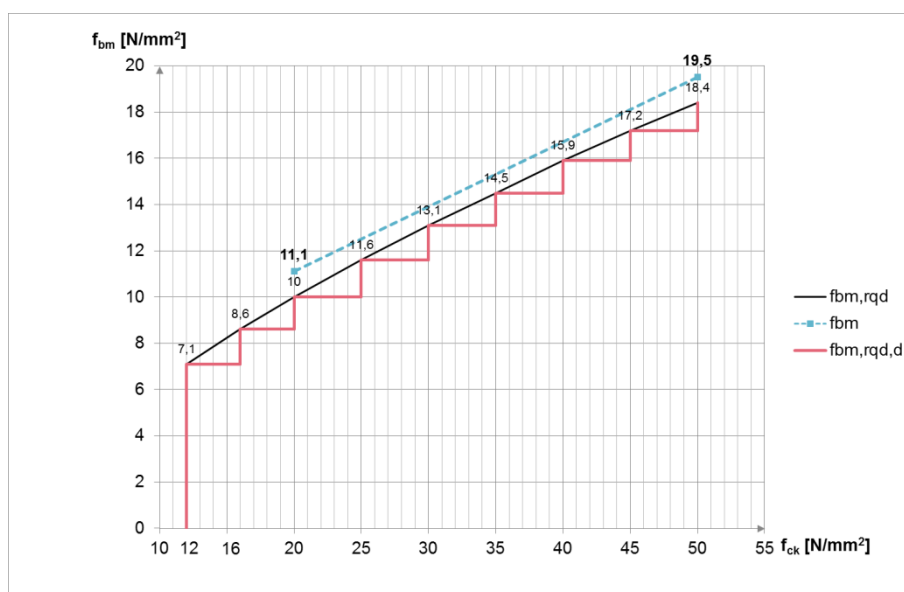

Figure 2.2 Example A: Design according to EN 1992-1-1 [1] without reduction

Table 2.2 Determination of k_b for example A

Concrete class	C12/15	C16/20	C20/25	C25/30	C30/37	C35/45	C40/50	C45/55	C50/60
f _{ck} [N/mm ²]	12	16	20	25	30	35	40	45	50
f _{bm} [N/mm ²]	8,9	10,0	11,1	12,5	13,9	15,3	16,7	18,1	19,5
f _{bm,rqd} [N/mm ²]	7,1	8,6	10,0	11,6	13,1	14,5	15,9	17,2	18,4
f _{bm,rqd,d} [N/mm ²]	7,1	8,6	10,0	11,6	13,1	14,5	15,9	17,2	18,4
k _b [-]	1,0	1,0	1,0	1,0	1,0	1,0	1,0	1,0	1,0
f _{bd,PIR} [N/mm ²] ¹⁾	1,6	2,0	2,3	2,7	3,0	3,4	3,7	4,0	4,3

¹⁾ see footnote to Table A.4

If the required bond resistance is not fulfilled in C20/25 and/or C50/60, the design may be carried out with deviations to EN 1992-1-1 [1] using reduced design values of the ultimate bond stress determined according to b).

Case b) Correction of limit bond stress f_{bd} according to EN 1992-1-1 [1]

If the required bond resistance in C20/25 and/or C50/60 is not fulfilled, the following procedure shall be carried out:

- Draw a straight line between the mean bond resistances $f_{bm,20}$ and $f_{bm,50}$
- Draw a step-shaped curve under this line with the given values of the required bond resistance $f_{bm,rqd}$ for the different concrete classes given in Table A.4 such, that this curve does not exceed the straight line.
- The values of the step-shaped curve represent the decisive required bond strength $f_{bd,rqd,d}$ for the corresponding concrete classes and provide the basis for the determination of the factor k_b .
- Determine the bond efficiency factor k_b according to equation (2.10).

Example B: see Figure 2.3

Example B shows the determination of the design bond resistance in terms of the bond efficiency factor k_b of a post-installed rebar where the mean bond resistance $f_{bm,50}$ does not reach the required bond resistance $f_{bm,rqd}$ for C50/60.

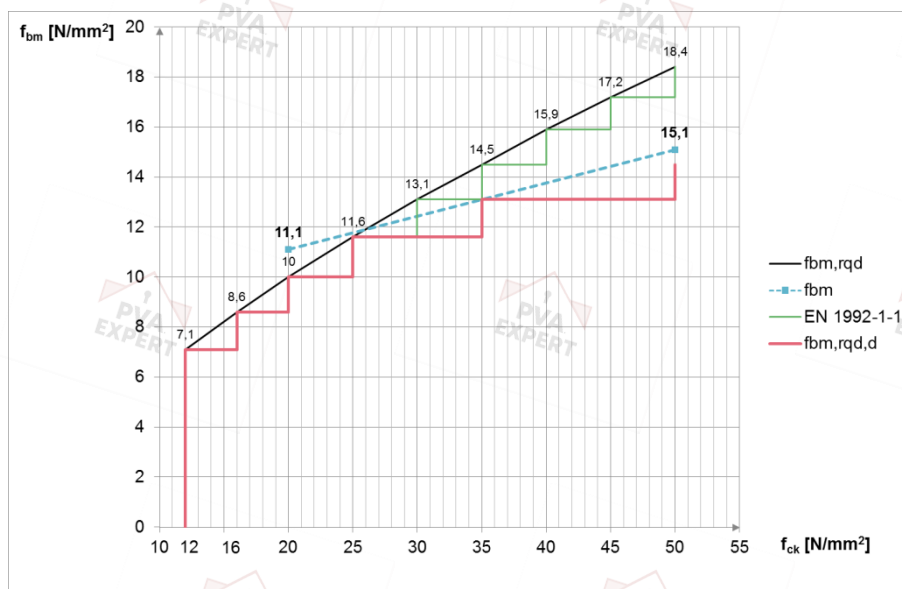

Figure 2.3 Example B, required bond resistance for C50/60 is not reached

Table 2.3 Determination of k_b for example B

Concrete class	C12/15	C16/20	C20/25	C25/30	C30/37	C35/45	C40/50	C45/55	C50/60
f_{ck} [N/mm ²]	12	16	20	25	30	35	40	45	50
f_{bm} [N/mm ²]	-	-	11,1	11,8	12,4	13,1	13,8	14,4	15,1
$f_{bm,rqd}$ [N/mm ²]	7,1	8,6	10,0	11,6	13,1	14,5	15,9	17,2	18,4
$f_{bm,rqd,d}$ [N/mm ²]	7,1	8,6	10,0	11,6	11,6	13,1	13,1	13,1	14,5
k_b [-]	1,0	1,0	1,0	1,0	0,89	0,90	0,82	0,76	0,79
$f_{bd,PIR}$ [N/mm ²] ¹⁾	1,6	2,0	2,3	2,7	2,7	3,0	3,0	3,0	3,4

¹⁾ see footnote to Table A.4

Example C: see Figure 2.4

Example C shows the determination of the design bond resistance in terms of the bond efficiency factor k_b where the mean bond resistances $f_{bm,20}$ and $f_{bm,50}$ do not reach the required bond resistances $f_{bm,rqd}$ for C20/25 and C50/60, respectively.

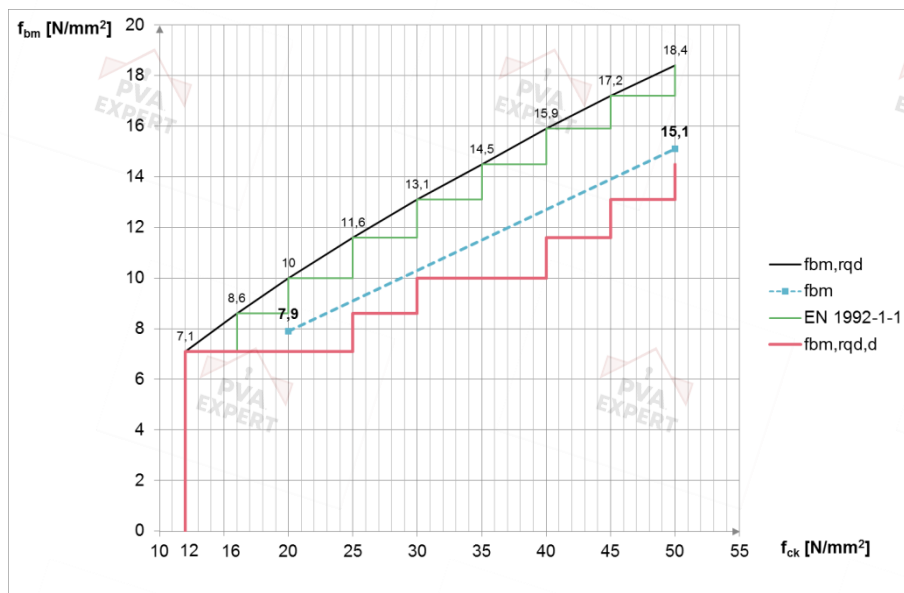

Figure 2.4 Example C, required bond resistances for C20/25 and C50/60 are not reached

Table 2.4 Determination of k_b for example C

Concrete class	C12/15	C16/20	C20/25	C25/30	C30/37	C35/45	C40/50	C45/55	C50/60
f_{ck} [N/mm ²]	12	16	20	25	30	35	40	45	50
f_{bm} [N/mm ²]	-	-	7,9	9,1	10,3	11,5	12,7	13,9	15,1
$f_{bm,rqd}$ [N/mm ²]	7,1	8,6	10,0	11,6	13,1	14,5	15,9	17,2	18,4
$f_{bm,rqd,d}$ [N/mm ²]	-	-	7,1	8,6	10,0	10,0	11,6	13,1	14,5
k_b [-]	-	-	0,71	0,74	0,76	0,69	0,73	0,76	0,79
$f_{bd,PIR}$ [N/mm ²] ^{*)}	-	-	1,6	2,0	2,3	2,3	2,7	3,0	3,4

^{*)} see footnote to Table A.4

Expression of results

Bond efficiency factor k_b [-]

The ETA shall explain the use of the bond efficiency factor k_b for post-installed rebar:

$$f_{bd,PIR} = k_b \cdot f_{bd} \quad (2.11)$$

Where

$f_{bd,PIR}$ = design bond strength of post-installed rebar

f_{bd} = design bond strength of cast-in rebar according to EN 1992-1-1 [1], 8.4.2

2.2.2.2 100 years working life: factor $k_{b,100y}$

Purpose of the assessment

The design value of the ultimate bond stress (design bond resistance) f_{bd} for ribbed bars (rebars) according to EN 1992-1-1 [1] depends on several National Determined Parameters.

The objective of this clause is to establish corrective coefficient $k_{b,100y}$, representing influence of the product on limit bond stress f_{bd} calculated according to EN 1992-1-1 [1], 8.4.2.”

Assessment method

The factor $k_{b,100y}$ assessed for 100 years working life is the same as k_b for 50 years working life ($k_{b,100y} = k_b$) if the following condition is fulfilled:

- The reduction factors α and α_p in the assessment according to 2.2.1.7 b) and 2.2.1.8.b) are not smaller than 1,0.

Otherwise, the assessment follows section 2.2.2.1 using the results of section 2.2.1.7 b) and 2.2.1.8.b) and determine the factor for 100 years working life. For distinction of different assessments use the additional index 100y in all terms (e.g.: $k_{b,100y}$, $f_{bm,rqd,d,100y}$, $f_{bd,PIR,100y}$).

$$k_{b,100y} = \frac{f_{bm,rqd,d,100y}}{f_{bm,rqd}} \leq 1,0 \quad (2.12)$$

Expression of results

Bond efficiency factor $k_{b,100y}$ [-]

The ETA shall explain the use of the reduction factor $k_{b,100y}$ for post-installed rebar (see also 2.2.2.1):

$$f_{bd,PIR,100y} = k_{b,100y} \cdot f_{bd} \quad (2.13)$$

2.2.3 Amplification factor for minimum anchorage length (Test series Table A.1, lines 3 to 6)

Purpose of the assessment

Cast-in place and post-installed rebars may show a different behaviour in cracked concrete. To account for this difference the minimum anchorage length $l_{b,min}$ and minimum lap length $l_{o,min}$ given in EN 1992-1-1 [1], 8.4.4 and 8.7.3, respectively, shall be multiplied by the amplification factor α_{lb} .

Investigations have shown that the bond resistance of cast-in-place rebar in cracked concrete is about 75% of the value valid for uncracked concrete **Error! Reference source not found.** For post-installed rebar the bond resistance in cracked concrete is about 50% of the value in uncracked concrete. For certain post-installed rebar systems, however, the influence of cracks on the bond resistance may be smaller. Therefore, the increase in the minimum bond length for anchorages or overlap splices may be smaller or omitted at all under certain conditions.

Assessment method

Test procedure

The amplification factor α_{lb} may be determined through testing in cracked concrete. The tension tests shall be performed in cracked concrete C20/25 and C50/60 ($\Delta w = 0,3$ mm) with a setting depth of the bar of $l_v = 10 \phi$. The crack shall be constant throughout the member thickness. It shall be ensured (e.g., by an endoscope) that the crack runs throughout the whole setting depth. The tension tests shall be performed with a rebar diameter of $\phi = 12$ mm and $\phi = \phi_{max}$.

Assessment

a) 50 years working life - factor α_{lb}

If no tests according to Table A.1, line 3 to 6 in cracked concrete were performed, the following default levels for the amplification factor α_{lb} shall be used:

$$\alpha_{lb} = 1,5$$

$$\alpha_{lb} = 1,0 \quad \text{only if the bond strength in uncracked concrete is by a factor of 1,5 larger than the required bond resistance for post-installed rebar } f_{bm,rqd} \text{ as it is given in Table A.14, i.e., } f_{bm,20} > 1,5 \cdot 10,0 = 15,0 \text{ N/mm}^2 \text{ for C20/25 and } f_{bm,50} > 1,5 \cdot 18,4 = 27,6 \text{ N/mm}^2 \text{ for C50/60.}$$

The amplification factor α_{lb} may also be determined by testing.

For the results of the tests performed in cracked concrete according to lines 3 to 6 of Table A.1 the following assessment applies to determine the amplification factor α_{lb} .

The mean bond resistance in cracked concrete C20/25 and C50/60 is determined according to equation (A.2) resulting in $f_{bm,cr,t,20}$ and $f_{bm,cr,t,50}$, respectively. Using the same approach as in 2.2.2.1 the mean bond resistance in cracked concrete $f_{bm,cr,t}$ for intermediate concrete strength classes is calculated using linear interpolation (based on the concrete cylinder strength).

For each concrete strength class, the required bond strength in cracked concrete shall be determined according to equation (2.14).

$$f_{bm,cr,rqd} = \frac{0,75 \cdot f_{bm,rqd,d}}{\alpha_4 \cdot \min \beta_{cv} \cdot \min(\min \alpha_p; \min \frac{\alpha}{rqd \cdot \alpha})} \quad (2.14)$$

The amplification factor α_{lb} for each concrete strength class shall be calculated as given in equation (2.15) and rounded to the nearest tenth according to mathematical rules.

$$\alpha_{lb} = \frac{f_{bm,cr,rqd}}{f_{bm,cr,t}} \geq 1,0 \quad (2.15)$$

The smaller value α_{lb} as tested with size $\phi = 12$ mm and max ϕ shall be applied to neighbouring sizes untested. Nevertheless, it is allowed to determine additional intermediate sizes.

Minimum anchorage length:

$$l_{b,PIR,min} = \alpha_{lb} \cdot l_{b,min}$$

$l_{b,min}$ = minimum anchorage length of cast-in rebar according to EN 1992-1-1 [1], 8.4.4

Minimum lap length:

$$l_{0,PIR,min} = \alpha_{lb} \cdot l_{0,min}$$

$l_{0,min}$ = minimum lap length of cast-in rebar according to EN 1992-1-1 [1], 8.7.3

b) 100 years working life - factor $\alpha_{lb,100y}$

If no tests according to Table A.1, line 3 to 6 in cracked concrete were performed, the following default levels for the amplification factor α_{lb} shall be used:

$$\alpha_{lb,100y} = 1,5$$

$$\alpha_{lb,100y} = 1,0 \quad \text{The default value can be only taken without further testing if the bond strength in uncracked concrete is by a factor of 1,5 larger than the required bond resistance for post-installed rebar } f_{bm,rqd} \text{ as given in Table A.1 for low and high strength concrete, i.e., } f_{bm,20,100y} > 15,0 \text{ N/mm}^2 \text{ and } f_{bm,50,100y} > 27,6 \text{ N/mm}^2.$$

The amplification factor $\alpha_{lb,100y}$ may also be determined by testing.

For the results of the tests performed in cracked concrete according to lines 3 to 6 of Table A.1 the following assessment applies to determine the amplification factor α_{lb} .

The mean bond resistance in cracked concrete C20/25 and C50/60 is determined according to equation (A.2) resulting in $f_{bm,cr,t,20}$ and $f_{bm,cr,t,50}$, respectively. Using the same approach as in 2.2.2.2 the mean bond resistance in cracked concrete $f_{bm,cr,t}$ for intermediate concrete strength classes is calculated using linear interpolation (based on the concrete cylinder strength).

For each concrete strength class, the required bond strength in cracked concrete shall be determined according to equation (2.16).

$$f_{bm,cr,rqd,100y} = \frac{0,75 \cdot f_{bm,rqd,d,100y}}{\alpha_4 \cdot \min \beta_{cv,100y} \cdot \min \left(\min \frac{\alpha}{rqd \cdot \alpha} \cdot \min \alpha_{p,100y} \right)} \quad (2.16)$$

where:

$f_{bm,rqd,d,100y}$: as determined in section 2.2.2.2

$\min \frac{\alpha}{rqd \cdot \alpha}$: as determined in section 2.2.1.12

The amplification factor α_{lb} for each concrete strength class shall be calculated as given in equation (2.15) and rounded to the nearest tenth according to mathematical rules.

$$\alpha_{lb,100y} = \frac{f_{bm,cr,rqd,100y}}{f_{bm,cr,t}} \geq 1,0 \quad (2.17)$$

The smaller value α_{lb} as tested with size $\phi = 12$ mm and max ϕ shall be applied to neighbouring sizes untested. Nevertheless, it is allowed to determine additional intermediate sizes.

Minimum anchorage length:

$$l_{b,PIR,min} = \alpha_{lb,100y} \cdot l_{b,min}$$

$l_{b,min}$ = minimum anchorage length of cast-in rebar according to EN 1992-1-1 [1], 8.4.4

Minimum lap length:

$$l_{0,PIR,min} = \alpha_{lb,100y} \cdot l_{0,min}$$

$l_{0,min}$ = minimum lap length of cast-in rebar according to EN 1992-1-1 [1], 8.7.3

Expression of results

Amplification factor for minimum anchorage length and lap length α_{lb} [-], $\alpha_{lb,100y}$ [-]

2.2.4 Bond strength under seismic loading, seismic bond efficiency factor (test series S1 and S2)

Purpose of the assessment

Determination of bond strength under seismic loading and seismic bond efficiency factor.

Assessment method

These test series are performed with post-installed rebars for the minimum (series S1) and the maximum (series S2) concrete strength for which assessment is sought. The test is designed on the assumption of general comparability to bond properties of cast-in rebar.

Test conditions

The tests shall be performed both in uncracked concrete of strength class C16/20 if the manufacturer does not specify a higher minimum concrete strength class AND in strength class C50/60, if the manufacturer does not specify a smaller maximum concrete strength class.

If the tests in maximum strength concrete (e.g., C50/60) are not performed, the design bond stress applicable for the minimum concrete strength shall be used for higher concrete grades.

The tests shall be performed with rebar sizes ϕ_{min} , ϕ_{med} and ϕ_{max} (see Table A.1). The cyclic tests with post-installed rebars shall be performed in uncracked concrete using a confined setup according to Annex B.

The displacements shall be measured at the unloaded end of the rebar as shown, for example, in Figure 2.5. The displacement is allowed to be measured at the loaded end of the bar as close as possible to the concrete surface. In any case in test series S1 and S2 the displacements shall be measured in a consistent manner.

For this test series, rebars with higher yield strength (with f_R between 0,05 and 0,10 see [8]) may be used to avoid steel failure.

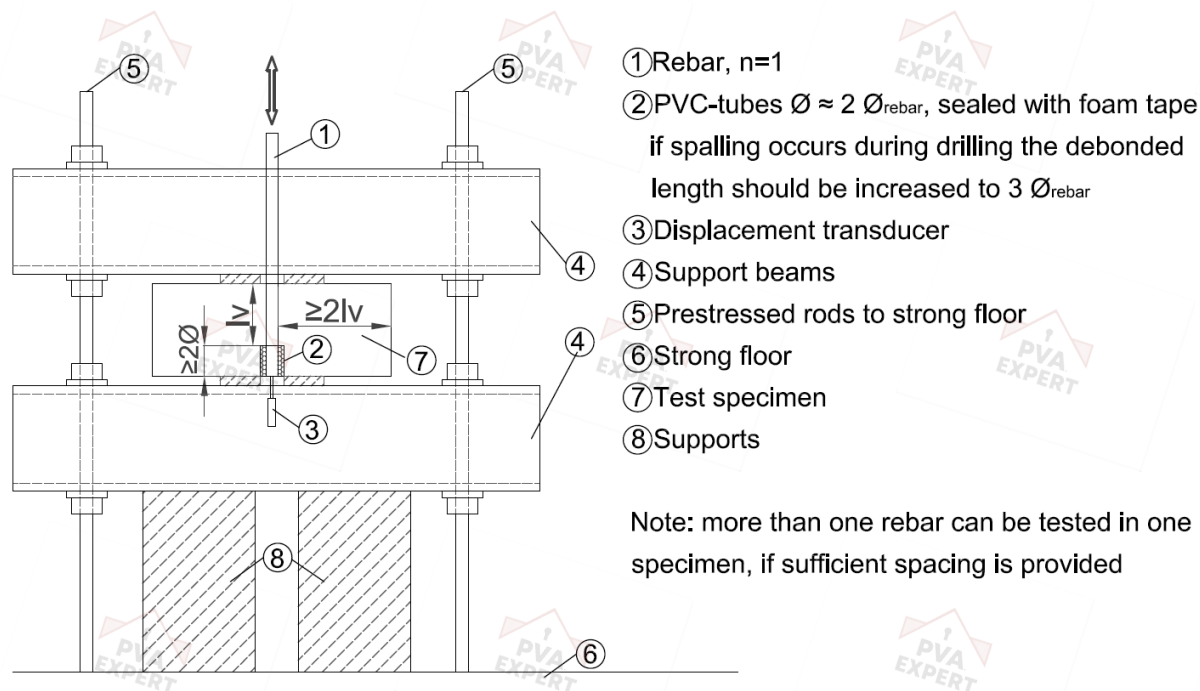

Figure 2.5 Example of pull-out test setup with displacement measurements at the unloaded end of the rebar

The tests shall be performed in displacement control using the required constant slip protocol (CSP) shown in Figure 2.6 a). The protocol consists in the application of ten displacement cycles between $+s_u$ (pull-out) and $-s_u$ (push-in) followed by a residual load test. The value of s_u needed to perform the cyclic tests shall be taken equal to the displacements δ_1 given in Table A.3.

Note 4 This loading protocol was developed and validated for cyclic testing of cast-in and post-installed rebars by several researchers in the past 30 years (e.g., Eligehausen et al. (1983) [19] and Simons (2007) [18])

During the test, the tension load (or bond stress) and the displacement relative to a fixed point outside of the concrete of the test specimen shall be continuously recorded and plotted as shown in Figure 2.6b). The cycling frequency shall be not higher than 0,5 Hz.

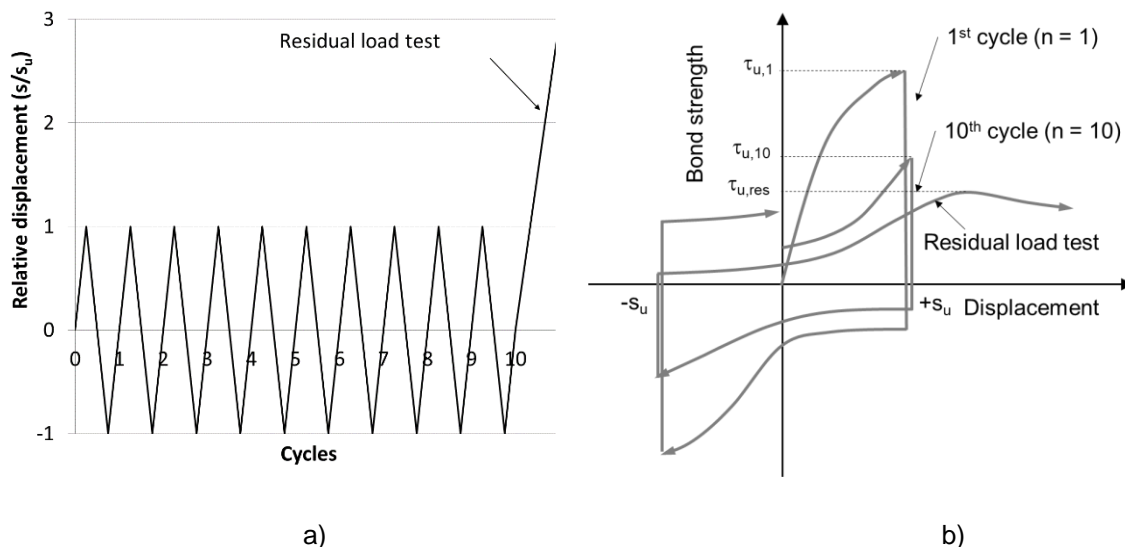

Figure 2.6: a) Displacement controlled loading protocol; b) Typical hysteretic behaviour of the bar (only cycles no. 1 and 10 are shown for clarity)

Assessment

Scatter of loads

The mean value of the maximum loads measured after cycle 1 in all tests of test series S1 and S2 shall be calculated. The coefficient of variation cv_F based on normal distribution shall be determined. Repeat this procedure for the maximum loads measured after cycles 2, 5, 10 and the residual load test.

If the coefficient of variation, cv_F , of the maximum loads after cycles 1, 2, 5, and 10 as well as the residual load in each test series 1 and 2 exceeds 20% and is not larger than 30%, the following reduction shall be taken into account:

$$\beta_{cv,seis} = 1/(1+0,03(cv_F-20)) \leq 1,0 \quad (2.18)$$

If cv_F exceeds 30% the number of tests shall be increased to meet this limit.

Scatter of failure displacements

The coefficient of variation of the displacement at peak of the residual failure load test cv_δ taken from any test series with post-installed rebars shall not be larger than 40%. If cv_δ exceeds 40% the number of tests shall be increased to meet this limit.

Conversion of ultimate loads to nominal strength

For this test series the bond stress after the i^{th} cycle ($i = 1, 2, 5$ and 10) shall be calculated using equation (A.2), replacing $N_{u,fc,m}$ with $N_{u,i}$, where $N_{u,i}$ is the maximum load measured for the i^{th} cycle in the tests and normalized to characteristic minimum and maximum strength concrete according to equation (2.19).

$$N_{u,i} = N_{u,i,test} \cdot \left(\frac{f_{ck}}{f_{c,test}} \right)^m \quad (2.19)$$

where

$N_{u,i,test}$ = measured maximum load for the i^{th} cycle in the bond tests

m = concrete strength normalization exponent for pull-out failures determined in accordance with EAD 330499 [4] Annex A. A value of $m = 0,3$ may be conservatively taken as default value in lieu of testing.

Equivalence in case of bond failure in low and high strength concrete

The mean of the maximum bond stress, $\tau_{um,i}$, achieved in the i^{th} cycle in the tests performed with post-installed rebar, shall be used to determine the factor $\alpha_{\text{seis,fc}}$ according to equations (2.20) and (2.21).

$$\alpha_{\text{test,i,fc}} = \frac{\tau_{um,i}}{f_{bm,rqd,fc} / \left(\alpha_4 \cdot \min \beta_{cv} \cdot \min(\min \alpha_p \cdot \min \left(\frac{\alpha}{rqd\alpha} \right)) \right)} \leq 1,0 \quad (2.20)$$

Where

$f_{bm,req,fc}$ = required bond resistance for post-installed rebars for the applicable concrete compressive strength according to Table A.4 (f_c refers to the specific concrete strength class as a line in Table A.4).

$$\alpha_{\text{seis,fc}} = \min(\alpha_{\text{test,i,fc}} / \alpha_i) \leq 1,0 \quad (2.21)$$

Where

α_i = bond strength degradation factor valid for cast-in rebars shown in Table 2.5

Table 2.5 Bond strength degradation factors for cast-in rebars.

Cycle no. (i)	Bond strength degradation factor, α_i [-] ¹⁾
1	1,00
2	0,55
5	0,35
10	0,25
Residual ultimate	0,40

¹⁾ α_i based on investigations by Simons (2007) [18]

The derived multiplying factors α_{seis} for the minimum and maximum concrete strength classes applied for shall be inserted in equations (2.22) as follows:

Calculate $f_{bm,seis}$, $k_{b,seis}$ and $f_{bd,PIR,seis}$ according to equation (2.22) and determine $f_{bm,rqd,d,seis}$ for each concrete strength class following the assessment given in 2.2.2.1.

In case of an assessment made for 100 years working life, use the parameters $f_{bm,seis,100y}$, $k_{b,seis,100y}$, $f_{bm,rqd,d,100y}$ and $f_{bd,PIR,seis,100y}$ determined with $f_{bm,red,d,100y}$ as determined in section 2.2.2.2.

$$f_{bm,seis} = \alpha_{\text{seis,fc,min}} \cdot \beta_{cv,seis} \cdot f_{bm} \quad (2.22)$$

where

f_{bm} = as determined in section 2.2.2.1

$$k_{b,seis} = \frac{f_{bm,rqd,d,seis}}{f_{bm,rqd}} \leq k_b \quad (2.23)$$

$$f_{bd,PIR,seis} = k_{b,seis} \cdot f_{bd} \quad (2.24)$$

In case equations (2.20) and (2.21) are determined for working life of 100 years, the parameters calculated from equations (2.22) and (2.23) are denominated as $k_{b,seis,100y}$ und $f_{bd,PIR,seis,100y}$.

If for a post-installed rebar $f_{bm,seis}$ is equal or larger than $f_{bm,rqd}$ according to Table A.4, $f_{bm,rqd,d,seis}$ shall be taken equal to $f_{bm,rqd}$ for concrete strength class under consideration.

Otherwise, if for a post-installed rebar $f_{bm,seis}$ is smaller than $f_{bm,rqd}$, $f_{bm,rqd,d,seis}$ is defined as the value of $f_{bm,rqd}$ applicable to the next lower concrete strength class that is exceeded by $f_{bm,seis}$.

Examples for the determination of k_b are given in section 2.2.2. $k_{b,seis}$ is to be determined in accordance with section 2.2.2, by replacing k_b with $k_{b,seis}$.

Expression of results

Bond strength under seismic loading $f_{bd,PIR,seis}$ [N/mm²], $f_{bd,PIR,seis,100y}$ [N/mm²]

Seismic bond efficiency factor $k_{b,seis}$ [-], $k_{b,seis,100y}$ [-]

2.2.5 Minimum concrete cover under seismic loading

2.2.5.1 Splitting failure under static loading (test series S3.1)

Purpose of the assessment

This test series addresses scenarios where the edge distances under seismic loading are smaller than the default edge distances according to Table 2.6.

Table 2.6 Default concrete cover $c_{min,seis}$

Design condition	Distance of 1 st edge	Distance of 2 nd edge
Edge	$\geq 4 \phi$	$\geq 8 \phi$
Corner	$\geq 6 \phi$	$\geq 6 \phi$

Assessment method

Tests are performed with cast-in rebars in the minimum concrete strength for which recognition is sought. The purpose is the derivation of the displacements to be applied in the cyclic tests with post-installed rebars (test series S3.2). The tests shall be conducted with rebars with a nominal diameter equal to 20 mm. The intention of this test is to generate pure splitting failure and to verify the equivalency with cast-in rebars at a minimum concrete cover $c_{min,seis} = 2\phi$. If these tests are not conducted, $c_{min,seis}$ according to Table 2.6 applies.

Test conditions

The tests shall be performed in uncracked concrete of strength class C16/20 if the manufacturer does not specify a higher minimum concrete strength class. The tests in each series (S3.1 and S3.2) shall be conducted in concrete of the same mixture and approximately the same compressive strength at the time of testing (± 5 MPa).

The tests shall be performed with rebar diameter $\phi = 20$ mm. However, if this size is not applied for, the closest rebar diameter applied for shall be used.

The tests shall be performed in uncracked concrete using the beam-end test specimen (BET, Figure 2.7) and an unconfined setup according to Annex B.1.2. The test setup according to Figure 2.7 (see also B.1.2) fulfils the following requirements:

- (a) unconfined test setup
- (b) splitting failure
- (c) minimum transverse reinforcement
- (d) minimum concrete cover $c_{min} = 2\phi$
- (e) The displacements shall be measured at the unloaded end of the rebars.
- (f) The tests shall be performed in displacement control.

The displacements depending on bond strength during the tests shall be recorded.

For this test series, rebars with higher yield strength (with f_R between 0,05 and 0,10 according to EN ISO 15630-1 [8]) may be used to avoid steel failure.

Perform a pull-out test of the rebar unto failure.

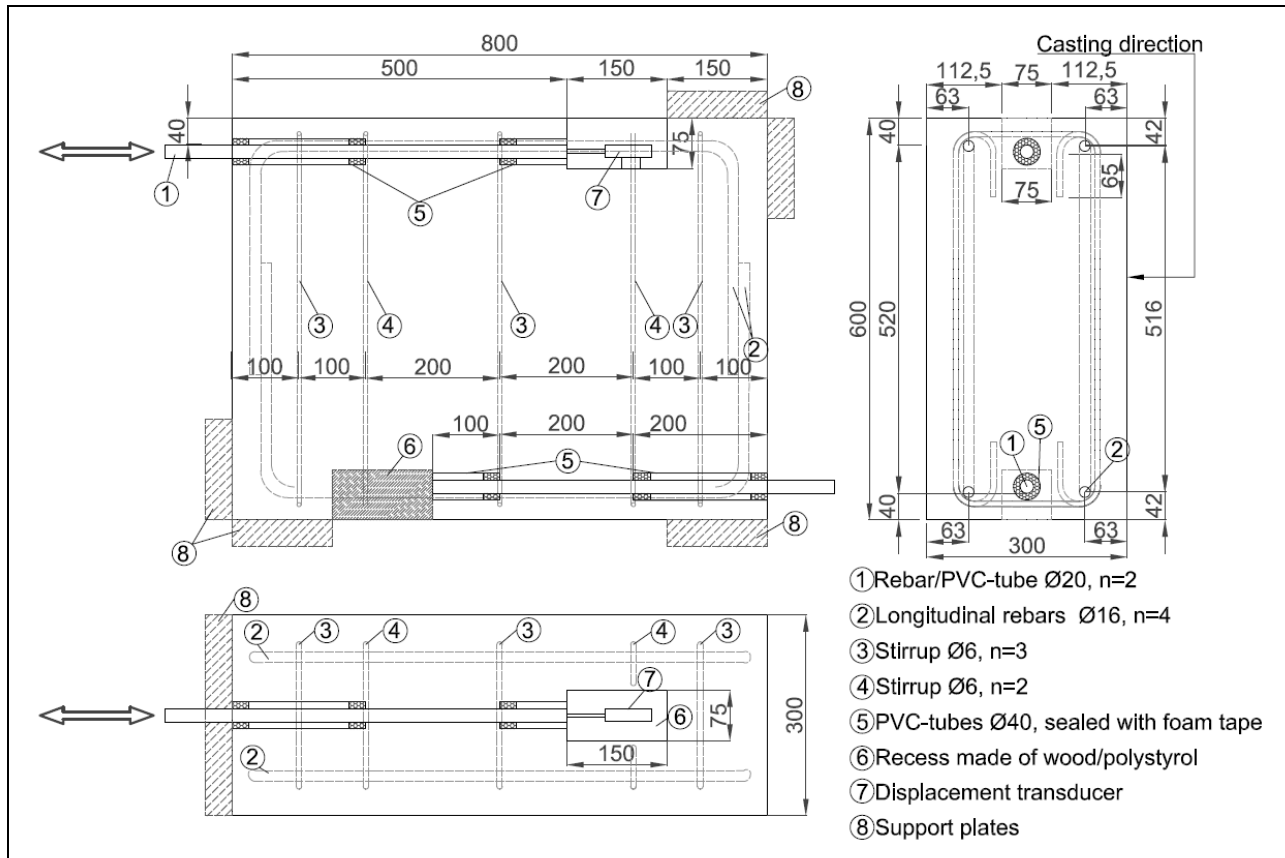

Figure 2.7: Beam-end test setup for rebar size $\phi = 20$ mm required to reach pure splitting failure

Assessment

In this chapter a value s_{max} is determined which will be needed for assessment of the cyclic loading part.

The displacement of the unloaded end of the rebar, s_{max} , shall be obtained in each test and its mean value shall be derived. The displacement s_{max} is defined as the larger of the following two values (Figure 2.8):

- The displacement $s_{80\%PP}$ corresponding to the point where the load/stress value drops down to 80% of its peak value in the post-peak region (see Figure 2.8a)
- The displacement $s = 2s_u$ denoting the displacement value twice the displacement reaches a value twice the value corresponding to the peak load/stress curve (see Figure 2.8b)

Note 5 This ensures that the post-peak behaviour of the system is properly checked.

The displacement s_{max} shall be obtained in each test and the mean value of this displacement shall be derived.

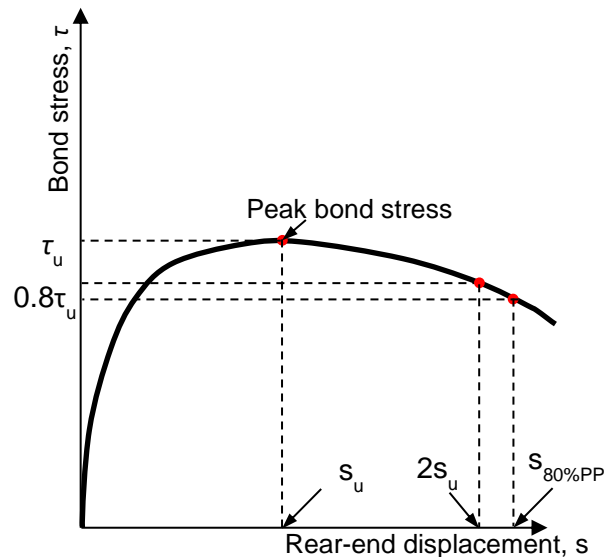
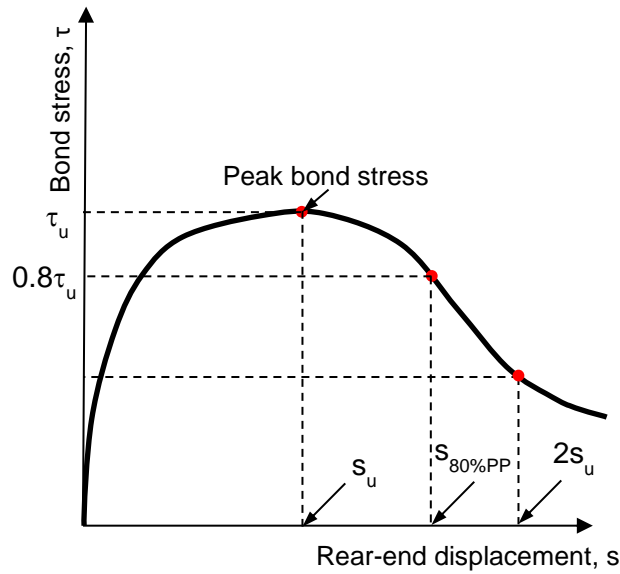

Example a) $2s_u > s_{80\%,PP}$

Example b) $s_{80\%,PP} > 2s_u$

Minimum slip until which the test shall be performed, $s_{max} = \max(s_{80\%,PP}; 2s_u)$

Figure 2.8: Determination of relevant slip values from monotonic tests on cast-in rebar, s_{max}

2.2.5.2 Splitting failure under seismic loading (test series S3.2)

Purpose of the assessment

These tests are performed with post-installed rebars in the minimum concrete strength for which assessment is sought. Their purpose is to verify comparability between the post-installed rebar and cast-in rebars in case of splitting failure. Comparability is established in terms of ultimate strength, energy dissipation, and residual load. The tests shall be conducted with rebars with a nominal diameter equal to 20 mm. If assessment for $\phi = 20$ mm is not sought, the rebar diameter closest to 20 mm shall be tested.

Assessment method

Test conditions

The tests shall be performed in uncracked concrete of strength class C16/20, if the manufacturer does not specify a smaller maximum concrete strength class. The tests in each series (S3.1 and S3.2) shall be conducted in concrete of the same mixture and approximately the same compressive strength at the time of testing (± 5 MPa)

The tests shall be performed with rebar diameter $\phi = 20$ mm. However, if this size is not applied for, the closest rebar diameter applied for shall be used.

The cyclic tests with post-installed rebars shall be performed using the test setup according to Figure 2.7 (Beam end test – BET) and an unconfined setup according to B.1.2. The displacements shall be measured at the unloaded end of the rebar as shown, for example, in Figure 2.7.

For this test series, rebars with higher yield strength (with f_R between 0,05 and 0,10) may be used to avoid steel failure.

The tests shall be performed in displacement control using the required increasing slip protocol (ISP) shown in Figure 2.9a). The protocol consists in the application of three displacement cycles between $s = 0$ and $s = s_{max}$ (pull-out) using increasing steps ($0,05 s_{max}$; $0,10 s_{max}$; $0,15 s_{max}$; $0,25 s_{max}$; $0,375 s_{max}$; $0,5 s_{max}$; $0,75 s_{max}$ and s_{max}) until the maximum axial displacement, s_{max} , followed by a residual pull-out test. The maximum axial displacement, s_{max} , until which the cyclic tests shall be performed is determined as $s_{max} = \max(s_{80\%PP}, 2 s_u)$, where $s_{80\%PP}$ and s_u are the mean values derived from the monotonic tests with cast-in rebar (test series S3.1 and Figure 2.8).

During the test, the load (or bond stress) and the displacement of the unloaded end relative to a fixed point outside of the concrete of the test specimen shall be continuously recorded and plotted in a manner similar to that shown in Figure 2.9b). The maximum loading rate shall allow reaching the displacement $0,5s_{max}$ in not less than 60 second.

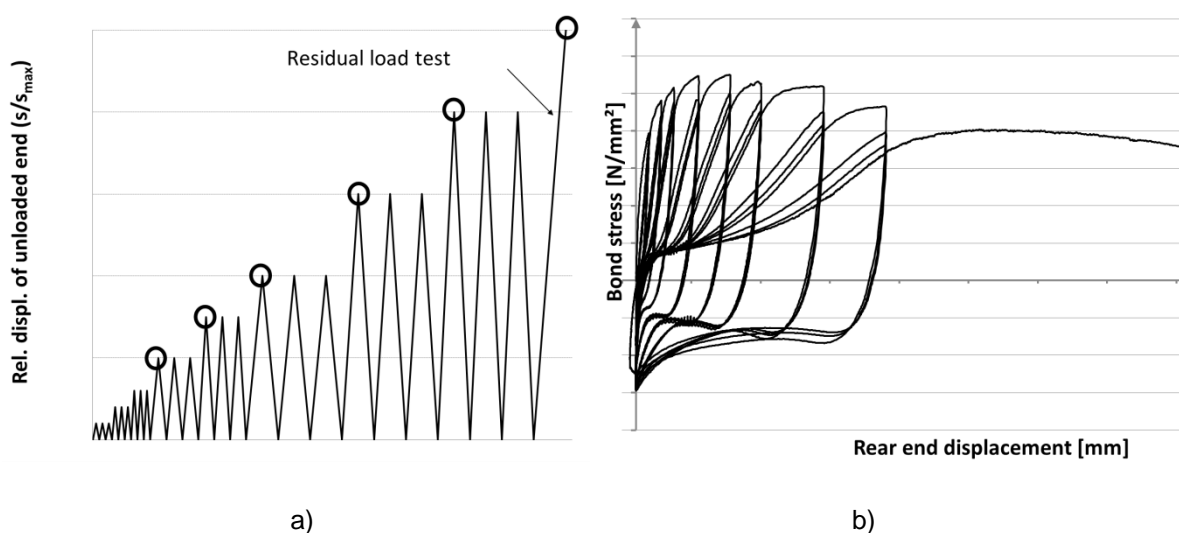

Figure 2.9 a) Displacement controlled loading protocol; b) Typical hysteretic behaviour of the bar
Assessment

Scatter of loads

The coefficient of variation of the maximum load after the first cycle cv_F at each incremental step $0,25s_{max}$, $0,375s_{max}$, $0,5 s_{max}$, $0,75 s_{max}$ and s_{max} (see marked points in Figure 2.9a)) as well as the residual strength in test series S3.2 shall not exceed 25%. If cv_F exceeds 25% the number of tests shall be increased to meet this limit.

Scatter of failure displacements

The coefficient of variation of the displacement at peak of the residual load tests in any test series with post-installed rebars shall not be larger than 40%. If cv_s exceeds 40 % the number of tests shall be increased to meet this limit.

Conversion of ultimate loads to nominal strength

The measured maximum load reached in each incremental step shall be normalized to the nominal concrete strength using equation (2.25):

$$N_{u,i} = N_{u,i,test} \cdot \left(\frac{f_{ck}}{f_{c,test}} \right)^{0,25} \quad (2.25)$$

Where

$N_{u,i,test}$ = measured maximum load for the 1st cycle of the ith level in the splitting tests (see marked points in Figure 2.9a))

2.2.5.3 Equivalence in case of splitting failure (test series S3.1 and S3.2)

Purpose of the assessment

The purpose is to verify comparability between the post-installed rebar and cast-in rebars in case of splitting failure. Comparability is established in terms of ultimate strength, energy dissipation, and residual load.

Assessment method

For this check the envelope of the cyclic bond stress-slip curves obtained from the tests on post-installed rebar shall be plotted by joining the peaks of the first cycles of each loading step (see Figure 2.9a). An example of the derivation of the envelope from the cyclic test results is shown in Figure 2.10.

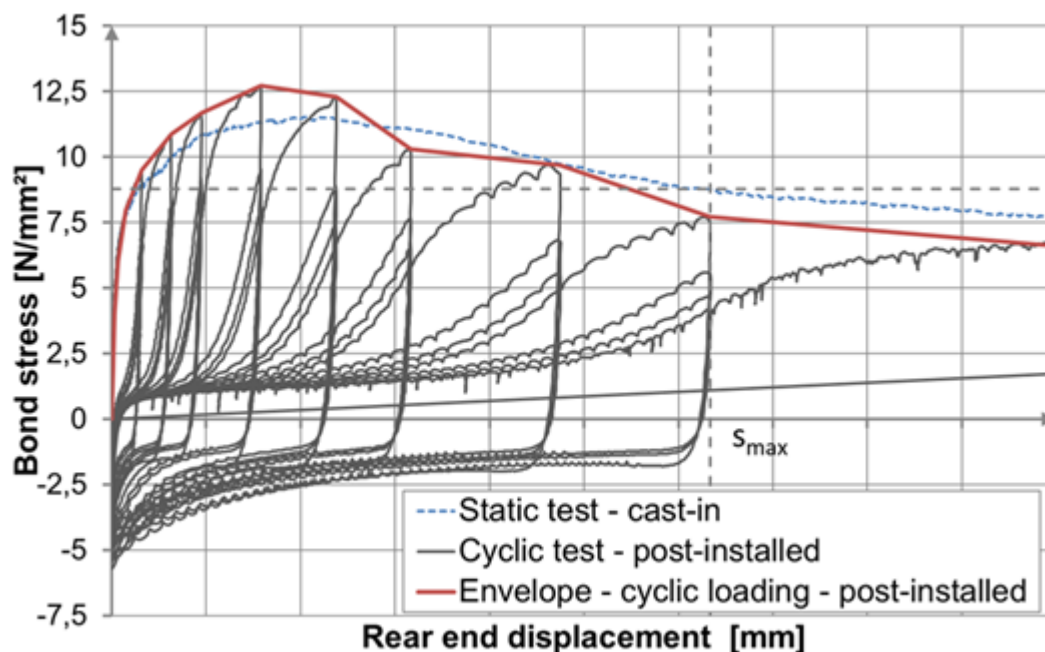

Figure 2.10 Derivation of envelope from measured cyclic load-displacement curves

The envelope of the cyclic load-displacement (or bond stress-slip) curve obtained for post-installed rebars shall be compared with the monotonic load-displacement (or bond stress-slip) curve obtained from the tests with cast-in rebar (Test series S3.1, Section 2.2.5.1).

The energy dissipated by the post-installed and cast-in rebar is compared between $s = 0$ and $s = s_{max}$ with s_{max} as defined in section 2.2.5.1.

The energy dissipated, E_n , by the systems is given by the areas under the load-displacement (or bond stress-slip) curves between $s = 0$ and $s = s_{max}$ (Figure 2.11).

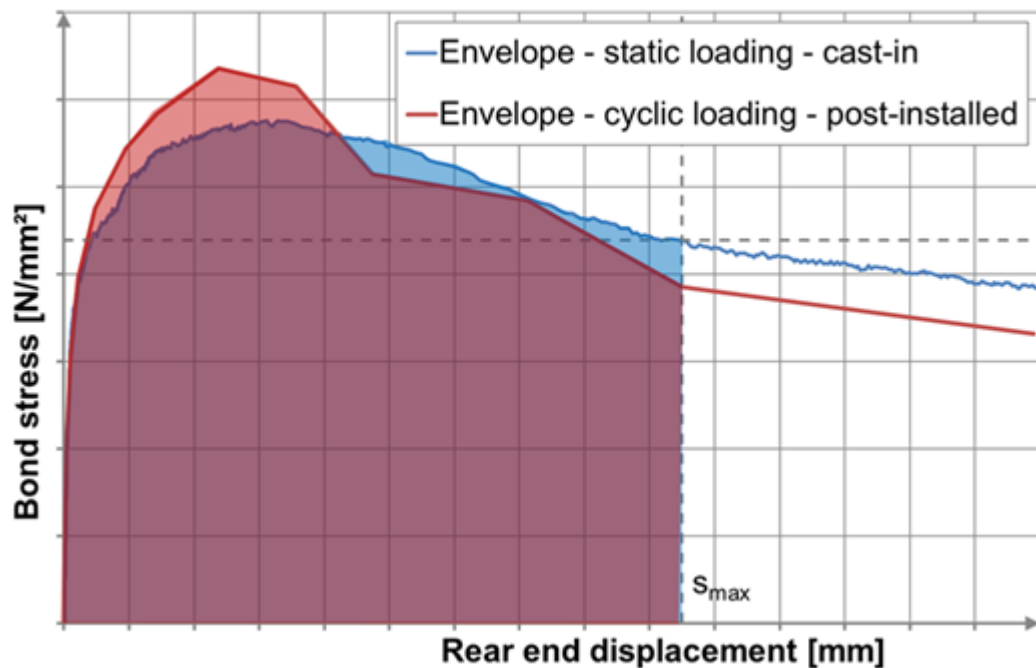

Figure 2.11: Energy dissipated by the system

The following criteria shall be satisfied to obtain equivalence:

$$1. \tau_{u,PIR,env} \geq \tau_{u,CI,stat} \quad (2.26)$$

$$2. E_{nPIR,env} \geq E_{nCI,stat} \quad (2.27)$$

$$3. \tau_{u,PIR,res} \geq 0,4\tau_{u,CI,stat} \quad (2.28)$$

Where

$\tau_{u,PIR,env}$ = mean ultimate bond strength (normalized to the minimum concrete strength class applied for using equation (2.25)) achieved by the post-installed rebar in the envelope of the cyclic tests

$\tau_{u,CI,stat}$ = mean ultimate bond strength (normalized to the minimum concrete strength class applied for using equation (2.25)) achieved by the cast-in rebar in the static tests

$E_{nPIR,env}$ = mean area under the envelope of the load-displacement (or bond stress-slip) curve obtained from cyclic tests on post-installed rebar

$E_{nCI,stat}$ = mean area under the load-displacement (or bond stress-slip) curve obtained from static tests on cast-in rebar

$\tau_{u,PIR,res}$ = mean ultimate bond strength (normalized to the minimum concrete strength class applied for using equation (2.25)) achieved by the post-installed rebar in the residual test after the completion of cyclic tests

If the requirements of equations (2.26) to (2.28) are satisfied, the post-installed rebar can be considered to be equivalent to cast-in rebars with respect to splitting. In this case, the minimum value of $c_{min,seis} = c_{min} \geq 2\phi$ with c_{min} according to Table 1.1 and Table 1.2 are valid.

This assessment is valid for a working life of 50 years as well as 100 years.

If any of the requirements of equations (2.26) to (2.28) is not satisfied, the edge distances under seismic loading are limited to the default edge distances according to Table 2.6.

Expression of results: Minimum edge distance in seismic applications: $c_{min,seis}$ [mm]

2.2.6 Characteristic resistance to steel failure for rebar tension anchors

Purpose of the assessment

Determination of characteristic resistance to steel failure for rebar tension anchors

Assessment method

The resistance to steel failure for rebar tension anchors shall be calculated for the smallest effective tensile stress area of each steel part (if rebar and partially or fully threaded bolt are different steels).

$$N_{Rk,s} = \min A_s \cdot f_{uk} \quad (2.29)$$

Where

$\min A_s$ = smallest effective tensile stress area of smooth shaft and metric threaded part.

f_{uk} = nominal ultimate strength of the corresponding steel

Expression of results:

Characteristic resistance to steel failure in seismic applications $N_{Rk,s}$ [kN]

2.2.7 Bond strength at increased temperature for post-installed rebar assessed for 50 years (test series 18)

Purpose of the assessment

The tests are intended to determine the resistance to fire of the post-installed rebar connection with mortar for working life 50 years. The anchorage length shall be determined in accordance with EN 1992-1-1 [1] equation (8.3) using the bond strength $f_{bd,fi}(\theta)$.

Assessment method

Test procedure

Test members

The tests are performed in uncracked concrete C20/25. The concrete used for testing shall comply with EN 206 [3] and meet the requirements of B1.1. The test setup is specified in Figure 2.12. Splitting of the concrete shall be prevented. Spalling of concrete shall not occur during the heating.

Dry concrete is required and therefore, the concrete test member shall be dried before testing. (this may be achieved by e.g., keeping cylinders under indoor ambient conditions for at least 3 months before testing, or storing at maximum +80°C until constant weight).

Installation

Drill and clean the hole, inject the mortar and insert the rebar at normal ambient temperature in accordance with the MPII. The diameter of the rebar ϕ shall be equal to 12 mm. The embedment depth of the rebar shall be equal to 120 mm.

If more than one drilling diameter is given in the MPII for the same rebar diameter, drilling shall be done with the largest drilling diameter.

Two type K thermocouples (TC1 and TC2) shall be positioned along the rebar at 10 mm from the concrete surface for TC1 and at the bottom of the rebar (120 mm below the concrete surface) for TC2. To ensure accuracy on the position of the thermocouples, TC1 and TC2 shall be positioned on the rebar before installation. Figure 2.12 presents the test member during thermal and mechanical loading.

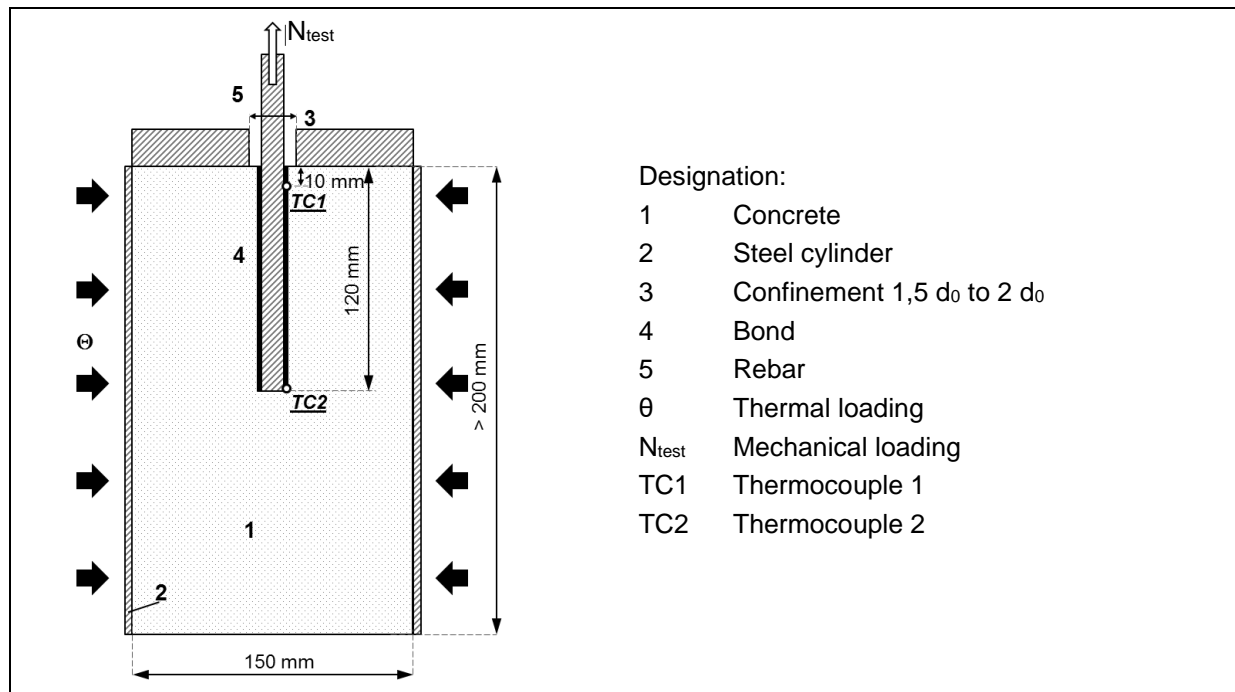

Figure 2.12 Test member during thermal and mechanical loading

General description of the test

The tests shall be performed within 2 weeks after the specified minimum curing time of the mortar (bonding material) has been reached. During this time period the test specimen shall be stored at normal ambient temperature. Position the member inside the test device. Apply a constant tension load N_{test} (see below for load levels) on the rebar and maintain the load throughout the duration of the test. Ensure that the load is kept constant (no minus tolerance); a servo controlled hydraulic jack with load control or dead load are suitable. The tension load is applied using a confined test setup according to Figure B.4 to avoid concrete cone failure. Apply thermal loading on the lateral sides of the concrete cylinder to heat up the concrete member at a minimum rate of 5°C/min, while maintaining the load N_{test} . Heating shall be continuously applied until pull-out of the rebar occurs (caused by the increase of the temperature of the mortar).

The measurement of the load N_{test} and of the temperatures of the bond (at TC1 and TC2) shall be recorded continuously during the heating test until pull-out occurs. The temperatures of the oven shall be recorded during the test.

Note 6 test setup with pull-out tests at stabilized temperature are under investigation at the time of elaboration of this EAD. Pre-tests show that the test results are not conservative, and research is being performed how to show the relationship.

The time of pull-out of the rebar shall be determined by the drop of load indicating failure and shall be recorded. The failure temperature $\theta_{failure}$ is calculated as the weighted average of the TC1 and TC2 temperatures when the pull-out occurs. The weighted average $\theta_{failure}$ is calculated as 1/3 of the higher measured temperature and 2/3 of the lower measured temperature. For each test, the failure temperature $\theta_{failure}$ is associated to the load N_{test} and corresponding bond stress $f_{b,t}$.

Thermal requirements

The main thermal flux shall be oriented towards the lateral side of the concrete cylinder. The non-bonded part of the rebar shall not be directly exposed to the heat source. This may be achieved by protecting the rebar with thermal insulating material.

The temperature of the oven shall be chosen to ensure the test duration of less than 3 hours in order to prevent excessive post curing of the mortar. Repeatability of the test procedure shall be ensured by using the same temperature increase of the oven for every test.

For average measured temperatures at the surface of the rebar between 21 °C and ≤ 50 °C, the difference between the temperatures of TC1 and TC2 shall not exceed 10°C.

Note 7 At temperatures higher than 50 °C at the locations TC1 and TC2 water vaporization at the outer layers of the concrete specimen (close to the encasing steel cylinder) can lead to temperature differences between TC1 and TC2 that can be higher than 10°C.

Load values

A minimum number of 20 tests shall be carried out. The tests shall be performed at different load levels. For each applied load N_{test} the corresponding bond stress $f_{b,t}$ is calculated according to equation (A.2), with N_{test} and $f_{b,t}$ replacing $N_{u,fc,m}$ and $f_{bm,t}$, respectively. The load levels shall be selected to ensure

- a) a maximum difference of the applied bond stress $f_{b,t}$ between two neighbouring data points in the interval $[1 \text{ N/mm}^2; f_{bm(21^\circ\text{C})}]$ of $\leq 1 \text{ N/mm}^2$, and
- b) a maximum difference of two neighbouring failure temperatures $\theta_{failure}$ of $\leq 50 \text{ }^\circ\text{C}$, and
- c) that the resulting fitting curve in the assessment provides the bond resistance at ambient temperature of $\geq f_{bm,rqd}$.

The confined pull-out tests at ambient temperature shall be carried out.

Figure 2.13 presents an example of the loads in terms of bond stress $f_{b,t}$ that may be used to establish the bond resistance vs. temperature relationship in the case of $f_{bm(21^\circ\text{C})} > 10 \text{ N/mm}^2$.

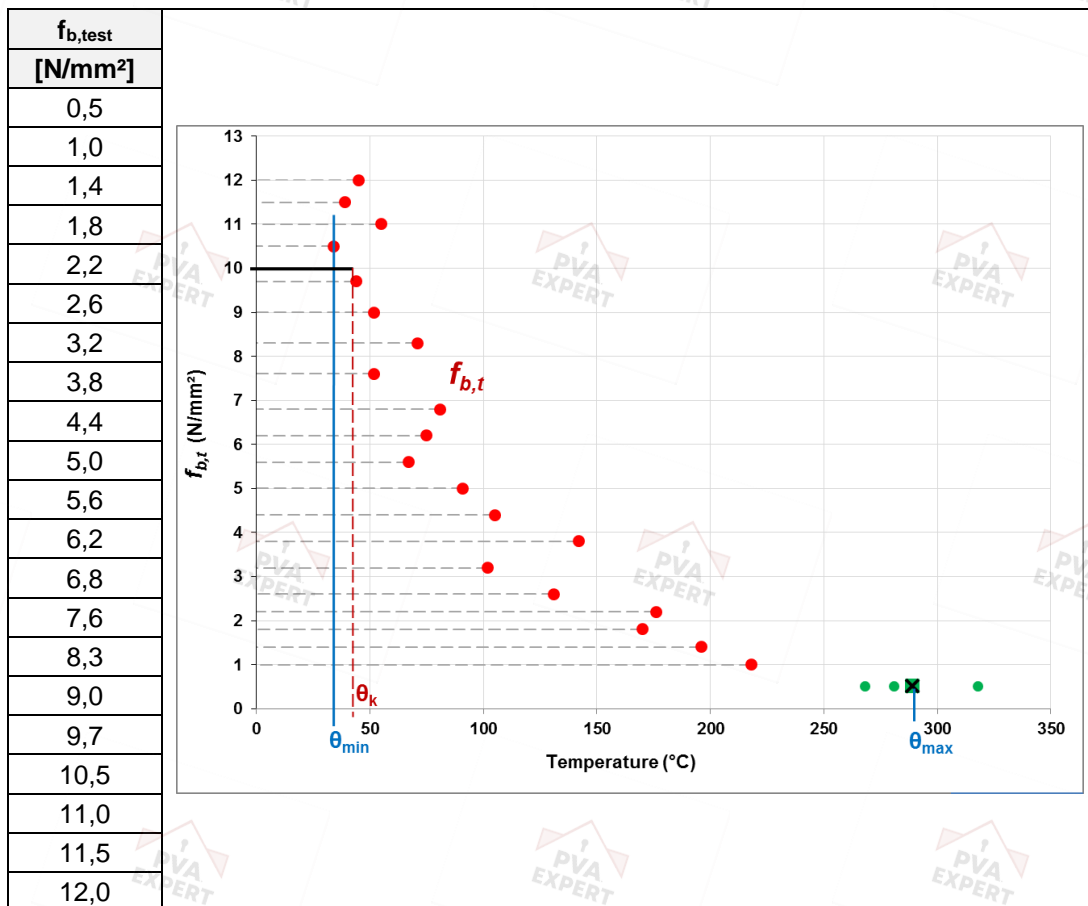

Figure 2.13 Example for bond stress $f_{b,t}$ vs. temperature at failure θ

Assessment of test results

Fitting curve

- a) If $f_{bm(21^{\circ}C)} \geq 10 \text{ N/mm}^2$, plot the variation of bond resistance vs. temperature. Determine the mean bond resistance f_{bm} with a best fitting trend function (exponential or power function are recommended; as an example, exponential function is given in equation (2.30)) using the least square fitting method. For low temperatures the fitting curve is cut to 10 N/mm². No extrapolation of the fitting curve shall be done beyond maximal temperatures θ_{max} measured during the tests.
- b) If $f_{bm(21^{\circ}C)} < 10 \text{ N/mm}^2$, add the 3 bond resistances measured at 21 °C to the bond resistance vs. temperature plot established with the high temperature tests. Determine the mean bond resistance f_{bm} with a trend function (exponential or power function are recommended; as an example, the exponential function is given in equation (2.30)) using the least square fitting method. For low temperatures the fitting curve is cut to $f_{bm,rqd}$ of concrete strength class C20/25. No extrapolation of the fitting curve shall be done beyond the maximal temperature θ_{max} measured during the tests.

$$f_{bm(\theta)} = a \cdot e^{-b \cdot \theta} \text{ [N/mm}^2\text{]} \tag{2.30}$$

The coefficient of variation cv shall be calculated as the relative deviation from the fitting curve according to equation (2.31).

$$cv = \sqrt{\frac{1}{n_{test} - 1} \sum_{i=1}^{n_{test}} \left(\frac{f_{b,t,i}}{f_{bm}(\theta_i)} - 1 \right)^2} \tag{2.31}$$

The coefficient of variation shall be $cv \leq 45 \%$. Increase of number of tests is allowed for better representation of the behaviour of the product

Figure 2.14 presents an example of the $f_{bm}(\theta)$ exponential curve fitted to the test data in the case where $f_{bm(21^{\circ}C)} > 10 \text{ N/mm}^2$.

The function may be chosen for best fit to test results:

Requirements for the chosen function

- No negative bond strength
- No increase of bond strength at high temperature
- No overestimation at high temperature
-

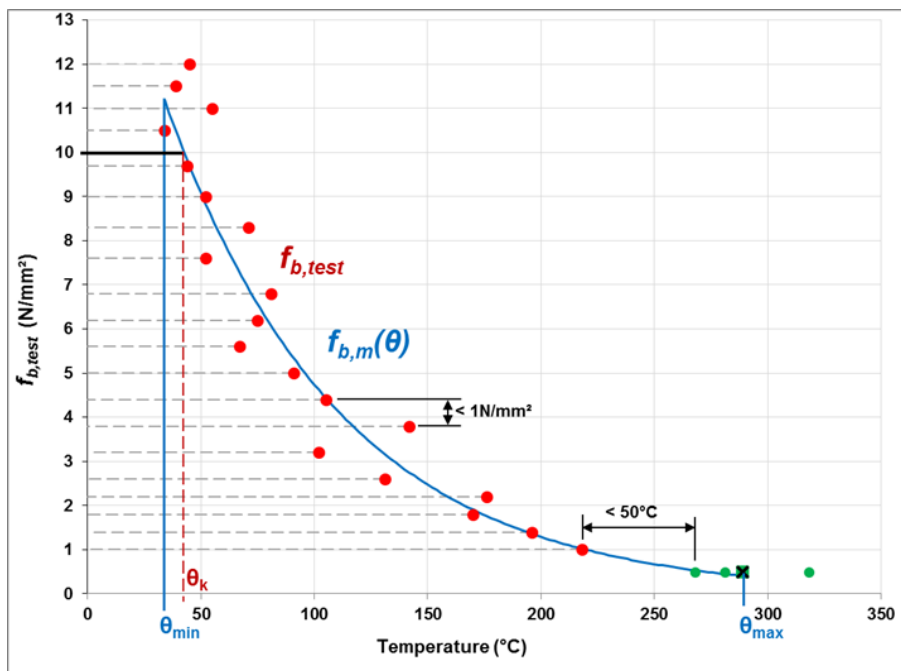

Figure 2.14 Example for determination of bond strength f_{bm} as a function of temperature θ
Temperature reduction factor

The temperature reduction factor $k_{fi}(\theta)$ shall be determined according to the following equations:

$$k_{fi}(\theta) = f_{bm}(\theta)/(f_{bd,PIR} \cdot 4,3) \leq 1,0 \text{ for } 21 \text{ } ^\circ\text{C} \leq \theta \leq \theta_{max} \quad (2.32)$$

$$k_{fi}(\theta) = 0 \text{ for } \theta > \theta_{max} \quad (2.33)$$

No extrapolation on test temperatures is allowed. For temperatures higher than the maximal measured temperature during the tests (θ_{max}), the reduction factor $k_{fi}(\theta)$ is equal to zero.

Figure 2.15 presents an example of the temperature reduction factor $k_{fi}(\theta)$ in the case where $f_{bm}(21^\circ\text{C}) > 10 \text{ N/mm}^2$. In this figure θ_k is the temperature up to which the mortar maintains the full capacity.

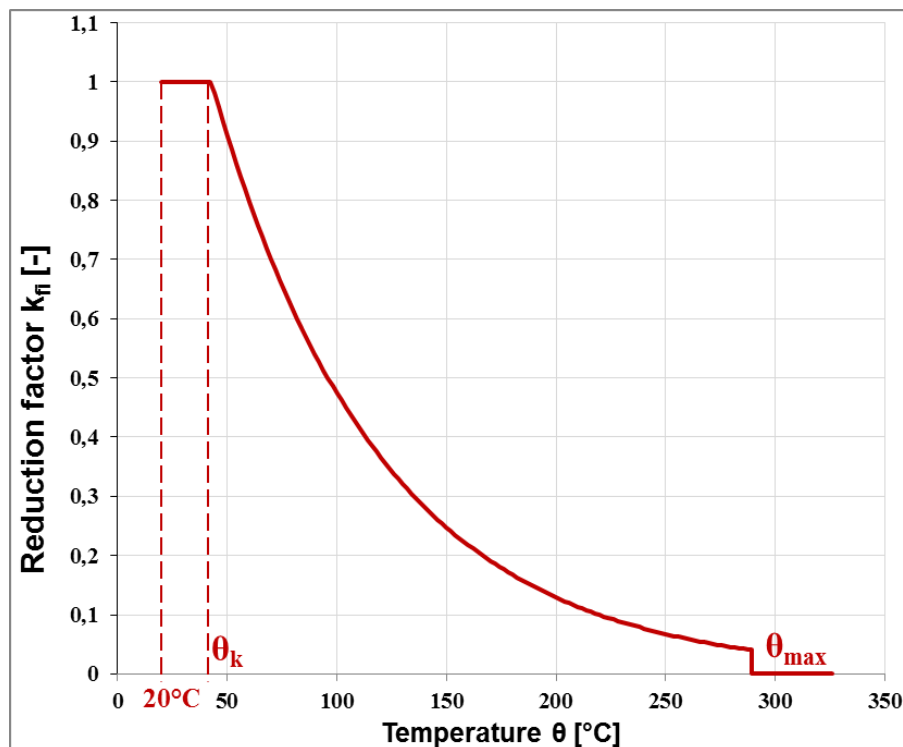

Figure 2.15 Example of the graph of reduction factor $k_{fi}(\theta)$ for concrete strength class C20/25 for good bond conditions

As a minimum requirement, the test report shall include at least the following information:

- The plots presenting the evolutions of the oven temperature, TC1 temperature, TC2 temperature and sustained load during the heating for each test.
- The test duration and the temperatures θ_{TC1} and θ_{TC2} at failure.
- If $f_{bm}(21^\circ\text{C}) < 10 \text{ N/mm}^2$, the bond resistances measured from the 3 tension tests performed at ambient temperature;
- The general data and information on test members, rebar installation and testing equipment described in Annex B.

As a minimum requirement, the evaluation report shall include at least the following information:

- The plot presenting bond stress vs. temperature with the fitting curve and the analytic equation of the fitting curve.
- The plot of the temperature reduction factor $k_{fi}(\theta)$ and the analytic equations that describe the variation of $k_{fi}(\theta)$ with temperature.
- The general data and information on test members, rebar installation and testing equipment described in Annex B.

Expression of results

The plot of the temperature reduction factor $k_{fi}(\theta)$ limited by 1,0 and maximum temperature θ_{max} as determined in Figure 2.15 and the analytic equations that describe the variation of $k_{fi}(\theta)$ with temperature.

Bond strength at increased temperature $f_{bd,fi}(\theta) = k_{fi}(\theta) \cdot f_{bd,PIR} \cdot \gamma_c/\gamma_{M,fi}$ [N/mm²]

Bond efficiency factor at increased temperature $k_{fi}(\theta)$ [-],

Maximal temperature θ_{max} [°C]

2.2.8 Bond strength at increased temperature for post-installed rebar assessed for 100 yearsPurpose of the assessment

The tests are intended to determine the resistance to fire of the post-installed rebar connection with mortar for working life 100 years. The anchorage length shall be determined in accordance with EN 1992-1-1 [1] equation (8.3) using the bond strength $f_{bd,fi,100y}(\theta)$.

Assessment method

The function $k_{b,100y}(\theta)$ assessed for 100 years working life is the same as $k_b(\theta)$ for 50 years working life ($k_{b,100y}(\theta) = k_b(\theta)$) if the following condition is fulfilled:

- The reduction factors α and α_p in the assessment according to 2.2.1.7 b) and 2.2.1.8.b) are not smaller than 1,0.

Otherwise, the assessment follows section 2.2.2.1 using the results of section 2.2.1.7 b) and 2.2.1.8.b) and determine the factor for 100 years working life. For distinction of different assessments use the additional index 100y in all terms (e.g.: $k_{b,100y}$, $f_{bm,rqd,d,100y}$, $f_{bd,PIR,100y}$).

Note 8 The function of bond strength over temperature according to section 2.2.7 also applies for an assumed working life of 100 years, but the bond resistance at normal ambient temperature may be different, depending on the results of 2.2.2, equation (2.8).

Expression of results

The plot of the temperature reduction factor $k_{fi,100y}(\theta)$ limited by 1,0 and maximum temperature θ_{max} as determined in Figure 2.15. and the analytic equations that describe the variation of $k_{fi,100y}(\theta)$ with temperature.

Bond strength at increased temperature $f_{bd,fi,100y}(\theta) = k_{fi,100y}(\theta) \cdot f_{bd,PIR,100y} \cdot \gamma_c/\gamma_{M,fi}$ [N/mm²]

Bond efficiency factor at increased temperature $k_{fi,100y}(\theta)$ [-],

Maximal temperature θ_{max} [°C]

2.2.9 Characteristic resistance to steel failure for rebar tension anchors under fire exposurePurpose of the assessment

Determination of characteristic resistance to steel failure for rebar tension anchors under fire exposure

Assessment method

The resistance to steel failure for rebar tension anchors under fire exposure shall be calculated for the smallest effective tensile stress area of each steel part (if rebar and partially or fully threaded bolt are different steels).

$$N_{Rk,s,fi} = \min A_s \cdot \sigma_{Rk,s,fi} \quad (2.34)$$

where

$\min A_s =$ smallest effective tensile stress area of smooth shaft and metric threaded part.

$\sigma_{Rk,s,fi}$ ultimate steel strength according to Table D.1 or D.2 of EN 1992-4 [11]

Expression of results

Characteristic resistance to steel failure for rebar tension anchors under fire exposure $N_{Rk,s,fi}$ [kN]

2.2.10 Reaction to fire

The post installed rebar is considered to satisfy the requirements for performance class A1 of the characteristic reaction to fire in accordance with the Decision 96/603/EC, as amended by commission Decision 2000/605/EC and 2003/424/EC, without the need for testing on the basis of it fulfilling the conditions set out in that Decision and its intended use being covered by that Decision.

Therefore, the performance of the product is Class A1.

The injection mortar is considered as a small component embedded in the concrete. In the end use of the application the reaction to fire class of the concrete is not influenced. Separate testing and classification are not necessary.

3 ASSESSMENT AND VERIFICATION OF CONSTANCY OF PERFORMANCE

3.1 System(s) of assessment and verification of constancy of performance to be applied

For the products covered by this EAD the applicable European legal act is Commission Decision 1996/582/EC.

The system is 1.

3.2 Tasks of the manufacturer

The cornerstones of the actions to be undertaken by the manufacturer of the product in the procedure of assessment and verification of constancy of performance are laid down in Table 3.1.

Table 3.1 gives guidance; the control plan depends on the individual manufacturing process and has to be established between TAB and manufacturer for each product.

Table 3.1 Control plan for the manufacturer; corner stones

No	Subject/type of control	Test or control method	Criteria, if any	Minimum number of samples	Minimum frequency of control
Factory production control (FPC) [including testing of samples taken at the factory in accordance with a prescribed test plan]*					
Bonding material					
1	Batch number and expiry date	visual check	Laid down in control plan	1	Each batch
2	Components	check material and the mass of components according to recipe			
3	Specific gravity / Density	Standardized method proposed by the manufacturer			
4	Viscosity				
5	Reactivity (gel time, where relevant: max. reaction temperature, time to max reaction temperature)				Each batch
6	Properties of raw material	(e.g., by infrared analysis)			initial testing and each change of batch
7	Performance of the cured bonding material	(e.g., tension test to failure)		3	Each batch
Rebar tension anchor					
8	Raw Material	Factory certificate	Laid down in control plan	-	Each batch
9	Dimensions	measurement		3 ¹⁾	Every manufacturing batch or 10000 elements (the lower control interval is decisive)
10	Tension test	EN ISO 17660-1 [14] EN ISO 15630-1 [8] EN ISO 6892-1 [15]		3 ¹⁾	

¹⁾ for a batch size of less than 1000 elements, the minimum number of samples is 1.

3.3 Tasks of the notified body

The cornerstones of the actions to be undertaken by the notified body of the product in the procedure of assessment and verification of constancy of performance are laid down in Table 3.2.

Table 3.2 Control plan for the notified body; corner stones

No	Subject/type of control	Test or control method	Criteria, if any	Minimum number of samples	Minimum frequency of control
Initial inspection of the manufacturing plant and of factory production control					
1	Notified Body will ascertain that the factory production control with the staff and equipment are suitable to ensure a continuous and orderly manufacturing of the mortar.	Verification of the complete FPC as described in the control plan agreed between the TAB and the manufacturer	According to Control plan	According to Control plan	When starting the production or a new line
Continuous surveillance, assessment and evaluation of factory production control					
2	The Notified Body will ascertain that the system of factory production control and the specified manufacturing process are maintained taking account of the control plan.	Verification of the controls carried out by the manufacturer as described in the control plan agreed between the TAB and the manufacturer with reference to the raw materials, to the process and to the product as indicated in Table 3.1	According to Control plan	According to Control plan	1/year

4 REFERENCE DOCUMENTS

- | | | |
|------|----------------------------|--|
| [1] | EN 1992-1-1:2011, EC 2 | Eurocode 2: Design of concrete structures – Part 1-1: General rules and rules for buildings |
| [2] | EN 1992-1-2:2011, EC 2 | Eurocode 2: Design of concrete structures - Part 1-2: General rules - Structural fire design |
| [3] | EN 206:2013+A1:2016 | Concrete - Specification, performance, production and conformity |
| [4] | EAD 330499-01-0601:12-2018 | Bonded rebars for use in concrete |
| [5] | EN 10088-1:2014 | Stainless steels - Part 1: List of stainless steels |
| [6] | EN 10088-3:2014 | Stainless steels - Part 3: Technical delivery conditions for semi-finished products, bars, rods, wire, sections and bright products of corrosion resisting steels for general purposes |
| [7] | EN ISO 6988:1994 | Metallic and other non-organic coatings - Sulfur dioxide test with general condensation of moisture |
| [8] | EN ISO 15630-1:2019 | Steel for the reinforcement and prestressing of concrete - Test methods - Part 1: Reinforcing bars, wire rod and wire (ISO 15630-1:2019) |
| [9] | EN 1998-1:2004 + AC:2009 | Eurocode 8: Design of structures for earthquake resistance: General rules, seismic actions and rules for buildings |
| [10] | EN 1993-1-4:2006 + A1:2015 | Eurocode 3: Design of steel structures, Part 1-4: General rules – Supplementary rules for stainless steels |
| [11] | EN 1992-4:2018 | Eurocode 2: Design of concrete structures –Part 4: Design of fastenings for use in concrete |
| [12] | EN 197-1:2011 | Cement – Part 1: Composition, specification and conformity criteria for common cements |
| [13] | EN 13791:2019 | Assessment of in-situ compressive strength in structures and precast concrete components |
| [14] | EN ISO 17660-1:2006 | Welding – Welding of reinforcing steel – Part 1: Load-bearing welded joints (ISO 17660-1:2006) |
| [15] | EN ISO 6892-1:2019 | Metallic materials – Tensile testing – Part 1: Method of test at room temperature (ISO 6892-2019) |
| [16] | EAD 330087-00-0601:05-2015 | EOTA European Assessment Document for systems for post-installed rebar connections with mortar |
| [17] | EN ISO/IEC 17025:2017 | General requirements for the competence of testing and calibration laboratories |

Further information and background for assessment methods is given in the following documents:

- | | | |
|------|--|--|
| [18] | Simons, I. | Verbundverhalten von eingemörtelten Bewehrungsstäben unter zyklischer Beanspruchung (Bond behavior of post-installed reinforcing bars subjected to cyclic loading), PhD Thesis, University of Stuttgart, 2007 (in German). |
| [19] | Eligehausen, R.; Popov, E. P.; Bertero, V. V.:1983 | Local bond stress slip relationships of deformed bars under generalized excitation, UCB/EERC -83-23 |
| [20] | Lewandowski, R. | Beurteilung von Bauwerksfestigkeiten an Hand von Betongütewürfeln und –bohrproben, Schriftenreihe der Institute für Konstruktiven Ingenieurbau der Technischen Universität Braunschweig, Heft 3, Werner Verlag, Düsseldorf, 1971 |

ANNEX A TEST PROGRAM AND GENERAL ASPECTS OF ASSESSMENT

A.1. Test program

Annex B shall be followed for test members, test setup and details of tests as far as applicable. Modifications are addressed in section 2.2.1 to 2.2.7, which overrule conflicting provisions in Annex B.

If the temperature is not specified for a test series, normal ambient temperature ($21\text{ °C} \pm 3\text{ °C}$) of the concrete member during the tests applies.

The required tests are given as an overview in Table A.1. All tension tests, with the exception of the test series S3.1 and S3.2 for minimum concrete cover under static and seismic loading in accordance with Table A.1, shall be performed with confined test setup according to Annex B. The members shall be chosen such that splitting of the concrete is avoided (e.g., dimensions of member, steel encased concrete cylinder).

All tests are done with deformed rebar with properties according to Annex C of EN 1992-1-1 [1] with $f_{yk} \geq 500\text{ N/mm}^2$ and a relative rib area f_R between 0,05 and 0,10 in uncracked concrete C20/25 and C50/60. For the test series (Table A.1, lines 3 to 6) cracked concrete is to be used. Deformed rebar with the same geometrical properties made of steel with higher strength may be used for the tests (except for the test series according to Table A.1, line 17).

In all tests the holes are drilled with the diameter $d_{cut,m}$ according to the specifications of the manufacturer. The holes are cleaned according to the MPII with the cleaning equipment specified by the manufacturer. Exceptions see “sensitivity to hole cleaning” tests according to Table A.1, lines 7 and 8. The mortar and the rebar are installed according to the MPII with the equipment specified in the MPII.

The tests shall be done using each drilling method applied for by the manufacturer. However, if the tests are done using hammer drilling, the results of the tests can also be used for compressed air drilling or rock drilling.

The tests shall be performed within 5 days after the specified minimum curing time of the mortar has been reached unless specified differently in the following sections.

Some test series and corresponding assessment of post-installed reinforcing bars are identical with the assessment methods for bonded fasteners. The assessment of bonded fasteners (which may include rebars as fasteners) is given in EAD 330499 [4].

Table A.1 Test program for post-installed rebar connections

Line	Purpose of test	Concrete strength class	Rebar size ϕ [mm]	l_v [mm]	Minimum number of tests	Criteria	Test procedure / assessment
Basic tension tests							
1	Reference tension tests in uncracked concrete	C20/25	all ¹⁰⁾	10 ϕ	5 each	$f_{bm} \geq 7,1$ [N/mm ²]	2.2.1.1
2		C50/60	ϕ_{max}	7 ϕ	5		
3	Reference tension tests in cracked concrete ($\Delta w = 0,3\text{ mm}$)	C20/25	12	10 ϕ	5	-	2.2.3
4			ϕ_{max}		5		
5		C50/60	12	7 ϕ	5		
6			ϕ_{max}		5		
Functioning under tension load with respect to							
7	Robustness in dry concrete	C20/25	s/m/l	10 ϕ	5 each	$r_{qd} \cdot \alpha \geq 0,8$	2.2.1.2

Line	Purpose of test	Concrete strength class	Rebar size ϕ [mm]	l_v [mm]	Minimum number of tests	Criteria	Test procedure / assessment
8	Robustness in wet concrete	C20/25	s/m/l	10 ϕ	5 each	req. $\alpha \geq 0,75$	2.2.1.3
9	Installation at minimum installation temperature ¹⁴⁾	C20/25	ϕ_{max}	max l_v	3		2.2.1.4
10	Installation at maximum installation temperature	C20/25	ϕ_{max}	max l_v	3		2.2.1.4
11	Correct injection	-	ϕ_{max}	max l_v	3		2.2.1.5
12	Vertical upwards installation direction	C20/25	ϕ_{max}	10 ϕ	5	req. $\alpha \geq 0,9$	2.2.1.6
13	Horizontal installation direction	C20/25	ϕ_{max}	10 ϕ	5	req. $\alpha \geq 0,9$	
14	Sustained loads	C20/25	12	10 ϕ	5	req. $\alpha \geq 0,9$	2.2.1.7
15	Freeze/thaw conditions	C50/60	12	7 ϕ	5	req. $\alpha \geq 0,9$	2.2.1.8
16	High alkalinity and sulphurous atmosphere	C20/25	12	-	3 x 10		2.2.1.9
17	Corrosion resistance of rebar	C20/25	12	70 mm	3		2.2.1.10
Resistance to fire							
18	Bond strength at increased temperature	C20/25	12	10 ϕ	20		2.2.7 2.2.8
Resistance to seismic action							
S1	Bond strength under seismic loading in low-strength concrete	min ($\geq C16/20$)	$\phi_{min},$ $\phi_{med},$ ϕ_{max}	7 ϕ	5		2.2.4
S2	Bond strength under seismic loading in high-strength concrete	max ($\leq C50/60$)	$\phi_{min},$ $\phi_{med},$ ϕ_{max}	7 ϕ	5		2.2.4
S3.1	Minimum concrete cover under static loading	min ($\geq C16/20$)	20	10 ϕ	3		2.2.5.1
S3.2	Minimum concrete cover under seismic loading	min ($\geq C16/20$)	20	10 ϕ	5		2.2.5.2

For certain test series according to Table A.1 a reduced range of tested sizes, indicated by "s/m/l" may be used. The number of diameters to be tested in this case depends on the number of requested sizes and is given in Table A.2.

Table A.2 Reduced range of tested sizes

Number of requested sizes	Numbers of diameters to be tested
≤ 5	3
6 to 8	4
9 to 11	5

A.2. Provisions for all test series

It is recommended that handling of tests and calibration items are performed in accordance with EN ISO/IEC 17025 [17].

To avoid “steel failure” in the tests rebars of a higher strength may be used as long as the functioning is not influenced. This condition is fulfilled if the geometry of the rebar of higher strength steel is identical with the specified rebar.

In cases where the use of high strength rebar is insufficient to prevent “steel failure” the embedment depth shall be reduced. This principle may overrule the required embedment depth given in Table A.1 except for the test series concerning sensitivity to installation (Table A.1, lines 7 and 8). To avoid steel failure in the tests with maximum embedment depth for injection type systems or nominal embedment depth for capsule type systems the following test procedure may be employed.

For the robustness tests (test series according to Table A.1, lines 7 and 8) larger embedment length for the cleaning procedure is required. For these tests use a test member consisting of two concrete blocks A and B stacked on the top of each other without a permanent connection as shown in Figure A.1 a). Drill the hole in accordance with the procedures described in the MPII. Clean the hole as described below for the specific test. Install the bonding material and the element (for capsule type systems) or the bonding material only (for injection type systems) in each case in accordance with the MPII with the equipment supplied by the manufacturer as shown in Figure A.1 b). Remove the upper block A and for injection type systems install the metal part (Figure A.1 c)). After curing perform the confined tension test.

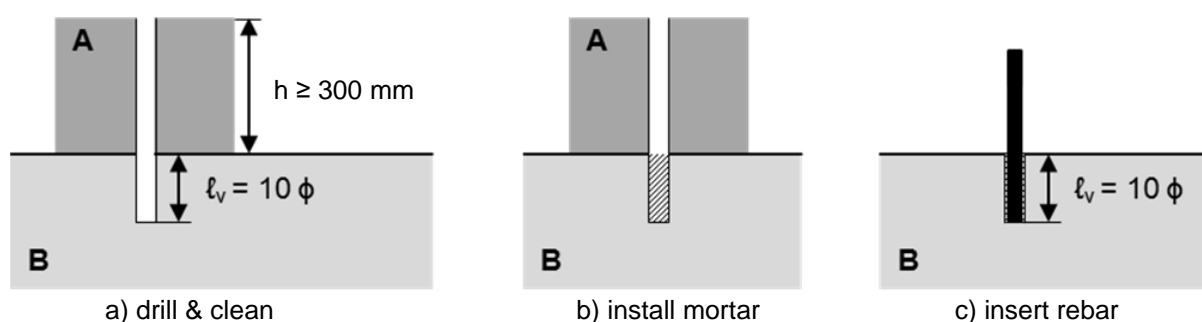

Figure A.1 Test set up to avoid steel failure

Reference tension tests shall be performed because they are needed for the evaluation of the results of the test series for resistance to pull-out failure and to take account of the influence of certain parameters on the resistance of bonded rebars to tension load. They shall be made in each batch. All reference tests shall be carried out as follows:

- in dry concrete

- at normal ambient temperature ($T = + 21^{\circ} \text{C} \pm 3^{\circ} \text{C}$)
- installation in accordance with the manufacturer's published instructions
- as confined test; they shall be made at approximately the same curing time as the corresponding tests.

The reference tests shall be made in the same concrete batch as the tests to which they shall be compared. The reference tests shall be made in uncracked concrete (cracked concrete: $\Delta w = 0,3 \text{ mm}$), if their results shall be compared with results of tests in uncracked concrete (cracked concrete).

It is necessary to carry out at least 5 reference tests in each test series for each concrete batch. Hence, the number of reference tests may need to be increased until the coefficient of variation meets the requirement.

If the assessment covers more than one drilling technique, all tests shall be done with all drilling techniques. If different sizes of packages, types of nozzles and dispensers will be used for one system, equal mixing of the bonding material components must be proven for all sizes of the packages and with all admissible types of nozzles and dispensers both for coaxial and shuttle cartridges.

A2.1 Installation

The rebar shall be installed in accordance with the MPII.

A2.2 Concrete strength and concrete age

The concrete strength at the time of testing the post-installed rebars shall be within the following limits:

$$\text{C16/20: } 20 \leq f_{c,\text{cube}} \leq 30 \text{ [N/mm}^2\text{]}$$

$$\text{C20/25: } 25 \leq f_{c,\text{cube}} \leq 35 \text{ [N/mm}^2\text{]}$$

$$\text{C50/60: } 60 \leq f_{c,\text{cube}} \leq 70 \text{ [N/mm}^2\text{]}$$

The concrete test member shall be at least 21 days old at the time of installation of the rebar and testing.

A2.3 Assessment of the failure mode

The test lab shall identify and report the initial failure mode for any test:

Tension tests:

- splitting (sp) – test condition for tests in uncracked concrete in case when a first crack of the concrete is observed
- bond failure between element and bonding material (be)
- bond failure between bonding material and bore hole (bb) (mixed bond failure between element and bonding material as well as between bonding material and bore hole (bbe) may occur)
- steel failure (s)

A2.4 Conversion of failure loads to nominal strength

The failure loads shall be converted as follows:

$$N_{u,fc} = N_{u,t} (f_{ck} / f_{c,t})^m \tag{A.1}$$

For pull-out failure $m = 0,3$ may be taken as a default value. Lower values shall be determined by comparison of test results in low strength and high strength concrete for diameters ϕ_{\min} , 12 mm and ϕ_{\max} .

A2.5 Mean bond resistance

The mean bond resistance for each tension test series according to Table A.1, lines 1 to 8, 12 to 15 and 18 is calculated from the results of the tension tests according to equation (A.2).

$$f_{bm} = \frac{N_{u,fc,m}}{\pi \cdot \varphi \cdot l_v} \cdot \left(\frac{0,08}{f_R} \right)^{0,4} \tag{A.2}$$

The parameter $N_{u,fc,m}$ is the mean value of the failure loads $N_{u,fc}$ in the test series. The failure (peak) load $N_{u,fc}$ of an individual test is determined as follows considering the limiting displacement δ_1 as given in Table A.3:

- If the peak load is reached at a displacement $\delta \leq \delta_1$, the peak load shall be used as failure load for the determination of $N_{u,fc,m}$.
- If the peak load is reached at a displacement $\delta > \delta_1$, use the load at δ_1 as failure load.
- Convert the failure load to the nominal strength (C20/25 or C50/60 depending on the test series) in accordance with A2.4.

Table A.3 Limiting displacement δ_1

ϕ [mm]	δ_1 [mm]
< 25	1,5
25 to 40	2,0
> 40	3,0

Note 9 The limiting displacements δ_1 are derived in **Error! Reference source not found.**

Note 10 If the peak load of post-installed rebar is reached at a displacement $\delta > \delta_1$ then the deformation of the post-installed rebar is larger than the one for a cast-in rebar and the one used in the basic assumptions (Bernoulli hypothesis) for the design.

A2.6 Criteria for bond strength

If the system has been assessed for use of rebar as a fastener according to EAD 330499 [4] these results may be used for assessment of post-installed rebar considering all relevant reduction factors and the required stress level.

The bond strength of the post-installed rebar system as assessed in section 2.2.1.1 to 2.2.1.10 shall be compared to the values given in Table A.4. Tests in which steel failure or steel yielding is observed shall not be considered for the assessment.

Table A.4 Bond strength of cast-in rebar

Concrete strength class	Bond strength $f_{bm,rqd}$ [N/mm ²]	Recommended design value of the ultimate bond stress according to EN 1992-1-1 f_{bd} [N/mm ²]
C12/15	7,1	1,6
C16/20	8,6	2,0
C20/25	10,0	2,3
C25/30	11,6	2,7
C30/37	13,1	3,0
C35/45	14,5	3,4
C40/50	15,9	3,7
C45/55	17,2	4,0
C50/60	18,4	4,3

Design values for the ultimate bond stress, f_{bd} , for ribbed bars (rebars) are determined based on Nationally Determined Parameters given in the National annex; the recommended values given here are calculated using equation (8.2) in clause 8.4.2 of EN 1992-1-1 [1], i.e., $f_{bd} = 2,25 \eta_1 \eta_2 f_{ctd}$, inserting the recommended

basic values for $\alpha_{ct} = 1,0$ (EN 1992-1-1, section 3.1.6) and $\gamma_c = 1,5$ (EN 1992-1-1, Table 2.1N) as well as $\eta_1 = \eta_2 = 1,0$ (EN 1992-1-1, section 8.4.2).

The design bond strength f_{bd} may deviate from Table A.4 if other Nationally Determined Parameters for α_{ct} , γ_c or η_1 are used. In this case, the expression of f_{bd} shall clearly indicate the appropriate National Annex of the Eurocode.

The European Technical Assessment shall include the following text:

- If Nationally Determined Parameter for α_{ct} differs from the recommended value given in EN 1992-1-1, f_{bd} shall be multiplied with α_{ct} .
- If Nationally Determined Parameter for γ_c differs from the recommended value given in EN 1992-1-1, f_{bd} shall be multiplied with $1,5/\gamma_c$.
- For all other than good bond conditions f_{bd} shall be multiplied with η_1 according to EN 1992-1-1, section 8.4.2
- For rebar diameter sizes > 32 mm f_{bd} shall be multiplied with η_2 according to EN 1992-1-1, section 8.4.2

Note 11 The bond strength $f_{bm,reqd}$ is based on large number of tests with cast-in-place rebar following the test regime of Table A.1, lines 1 and 2 and using concrete mixed according Annex B.

Note 12 The bond strength $f_{bm,reqd}$ is based on the design value of ultimate bond stress according to EN 1992-1-1 [1]. According to **Error! Reference source not found.** the value includes the following increasing factors taking into account the recommended material safety factor for concrete ($\gamma_{Mc} = 1,5$), the ratio of mean value to 5% fractile (1/0,75), the effect of uncracked concrete to bond in cracked concrete (1/0,75), the effect of large edge distance and spacing (1/0,7), and the influence of distribution of bond stress for short embedment as used in tests to long embedment (40 ϕ) according to EN 1992-1-1 [1] (1/0,8). The requirement given in Table A.1, line 1 corresponds to for the lowest concrete strength class C12/15 according to EN 1992-1-1 [1].

A2.7 Criteria regarding scatter of failure loads

If the coefficient of variation of the failure load in any test series according to Table A.1, lines 1 to 6 exceeds 15% and is not larger than 20%, the following reduction shall be considered:

$$\beta_{cv} = \frac{1}{1 + 0,03(cv - 15)} \leq 1,0 \quad (A.3)$$

If the coefficient of variation of the failure load in any test series according to Table A.1, lines 7, 8, 12 to 15 exceeds 20% and is not larger than 30%, the following reduction shall be taken into account:

$$\beta_{cv} = \frac{1}{1 + 0,03(cv - 20)} \leq 1,0 \quad (A.4)$$

The smallest result $\min \beta_{cv}$ in any test shall be taken for assessment.

A2.8 Sustained loads

If the stress applied on the rebar τ_p during a test series according to Table A.1, lines 14 and 15 is smaller than the required load, the reduction factor α_p shall be considered in the assessment. The smallest value α_p in any of these test series applies.

$$\alpha_p = \frac{\tau_{p,t}}{\tau_p} \leq 1,0 \quad (A.5)$$

With

$\tau_{p,t}$ actual stress applied on the rebar in the respective test series

τ_p stress required for the respective test series

A2.9 Failure loads (reduction factors α)

For test series according to Table A.1, lines 7, 8 and 12 to 15 the mean failure loads shall be compared with the corresponding reference test series of basic tension test series according to Table A.1:

$$\alpha = F_{u,m,t} / F_{u,m,r} \leq 1,0 \quad (\text{A.6})$$

A2.10 Loss of adhesion

With bonded rebars uncontrolled slip occurs when the bonding material with the embedded part is pulled out of the drilled hole (because then the load displacement behaviour depends significantly on irregularities of the drilled hole). The corresponding load when uncontrolled slip starts is called load at loss of adhesion $N_{u,adh}$.

The load at loss of adhesion $N_{u,adh}$ shall be evaluated in reference test series according to Table A.1 line 1 from the measured load displacement curve. The load at loss of adhesion is characterised by a significant change of stiffness, see Figure A.2). If the change in stiffness at a defined load is not so obvious, e.g., the stiffness is smoothly decreasing, the load at loss of adhesion shall be evaluated as follows:

- 1) Compute the tangent to the load-displacement curve at a load $0,3 N_u$ ($N_u =$ peak load in test). The tangent stiffness can be taken as the secant stiffness between the points $0/0$ and $0,3 N_u / \delta_{0,3}$ ($\delta_{0,3}$: displacement at $N = 0,3 N_u$).
- 2) Divide the tangent stiffness with a factor of 1,5.
- 3) Draw a line through the point $0/0$ with the stiffness as calculated in 2).
- 4) The point of intersection between this line and the measured load-displacement curve gives the load $N_{u,adh}$ where the adhesion fails, see Figure A.3.
- 5) If there is a peak in the load-displacement curve, to the left side of this line, which is higher than the load at intersection, $N_{u,adh}$ is taken as the peak load, see Figure A.4.
- 6) If there is a very stiff load-displacement curve at the beginning ($\delta_{0,3} \leq 0,05\text{mm}$) the drawing of the line for the calculation can be shifted to the point $(0,3 N_u / \delta_{0,3})$, see Figure A.5.

Examples of load-displacement curves

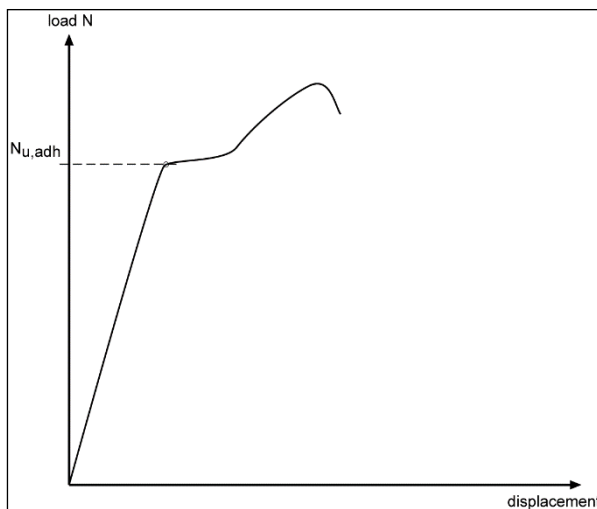

Figure A.2 Load at loss of adhesion by a significant change of stiffness

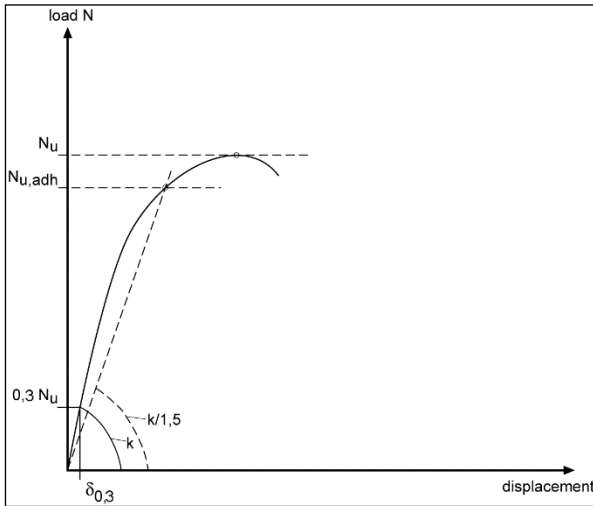

Figure A.3 Evaluation of load at loss of adhesion

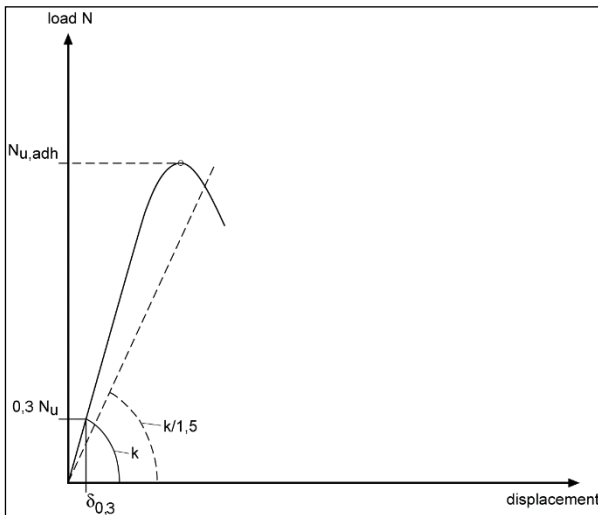

Figure A.4 Evaluation of load at loss of adhesion

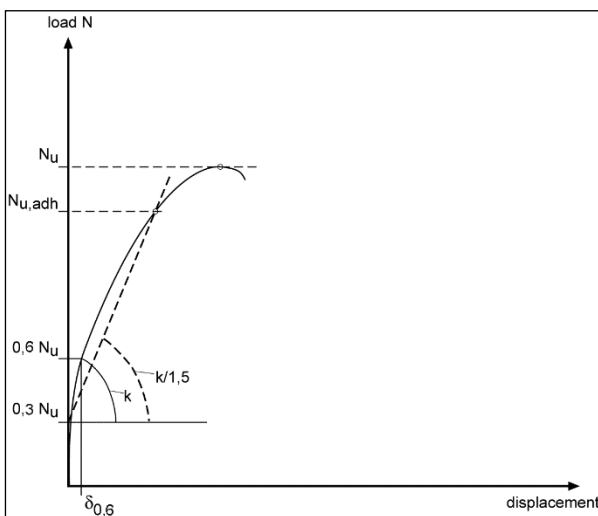

Figure A.5 Evaluation of load at loss of adhesion

$$C20/25 \quad f_c = \frac{1}{1,25} f_{cube} \quad (B.1)$$

$$C50/60 \quad f_c = \frac{1}{1,20} f_{cube} \quad (B.2)$$

For other dimensions, the concrete compressive strength may be converted as follows:

$$f_{cube100} = \frac{1}{0,95} f_{cube} \quad (B.3)$$

$$f_{cube} = \frac{1}{0,95} f_{cube200} \quad (B.4)$$

$$f_{cube} = f_{core100} \text{ (according to EN 13791 [13], section 7.1)} \quad (B.5)$$

Note 13 Additional literature for conversion is given by R. Lewandowski, Beurteilung von Bauwerksfestigkeiten an Hand von Betongüteküfeln und –bohrproben, Schriftenreihe der Institute für Konstruktiven Ingenieurbau der Technischen Universität Braunschweig, Heft 3, Werner Verlag, Düsseldorf, 1971 [20].

For every concreting operation, specimens (cylinder, cube) shall be prepared having the dimensions conventionally employed in the member country. The specimens shall be made, cured and conditioned in the same way as the test members.

Generally, the concrete control specimens shall be tested on the same day as the rebars to which they relate. If a test series takes a number of days, the specimens shall be tested at a time giving the best representation of the concrete strength at the time of the rebar tests, e.g., at the beginning and at the end of the tests. In this case the concrete strength at the time of testing can be determined by interpolation.

The concrete strength at a certain age shall be measured on at least 3 specimens. The mean value of the measurements governs.

If, when evaluating the test results, there are doubts whether the strengths of the control specimens represent the concrete strengths of the test members, then at least three cores of 100 mm diameter shall be taken from each of the test members outside the zone where the concrete has been damaged in the tests, and tested in compression. The cores shall be cut to a height equal to their diameter, and the surfaces to which the compression loads are applied shall be ground or capped. The compressive strength measured on these cores may be converted into the strength of cubes by equation (B.5).

B.1.1.6 Test members for tests in cracked concrete

The tests are carried out on test members with unidirectional cracks. The crack width shall be approximately constant throughout the member thickness. The thickness of the test member shall be $h \geq l_v + \min(30 \text{ mm}; 2\phi)$ but at least 100 mm. To control cracking, so-called 'crack inducers' may be built into the member, provided they are not situated near the anchorage zone. An example for a test member is given in Figure B.2.

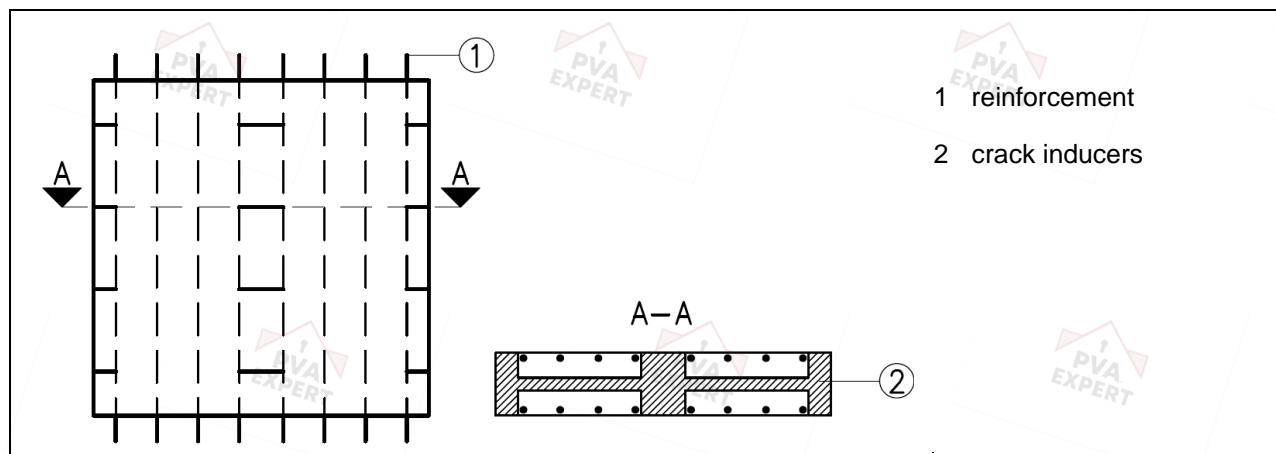

Figure B.2 Example of a test member for rebars tested in cracked concrete

B.1.1.7 Test members for tests in uncracked concrete

Generally, the tests are carried out on unreinforced test members. In cases where the test member contains reinforcement to allow handling or for the distribution of loads transmitted by the test equipment, the reinforcement shall be positioned such as to ensure that the loading capacity of the tested post-installed rebars is not affected. This requirement will be met if the reinforcement is located outside the zone of concrete cones having a vertex angle of 120° .

B.1.1.8 Casting and curing of test members

The test members shall be cast horizontally. They may also be cast vertically if the maximum height is 1,5 m and complete compaction is ensured.

Test members and concrete specimens (cylinders, cubes) shall be cured and stored indoors for seven days. Thereafter they may be stored outside provided they are protected such that frost, rain and direct sun does not cause a deterioration of the concrete compression and tension strength. When testing the rebars the concrete shall be at least 21 days old.

Test members and concrete specimen shall be stored in the same way.

B.1.2 Unconfined test setup

Unconfined tests allow an unrestricted formation of the rupture concrete cone. An example for an unconfined test setup is shown in Figure B.3.

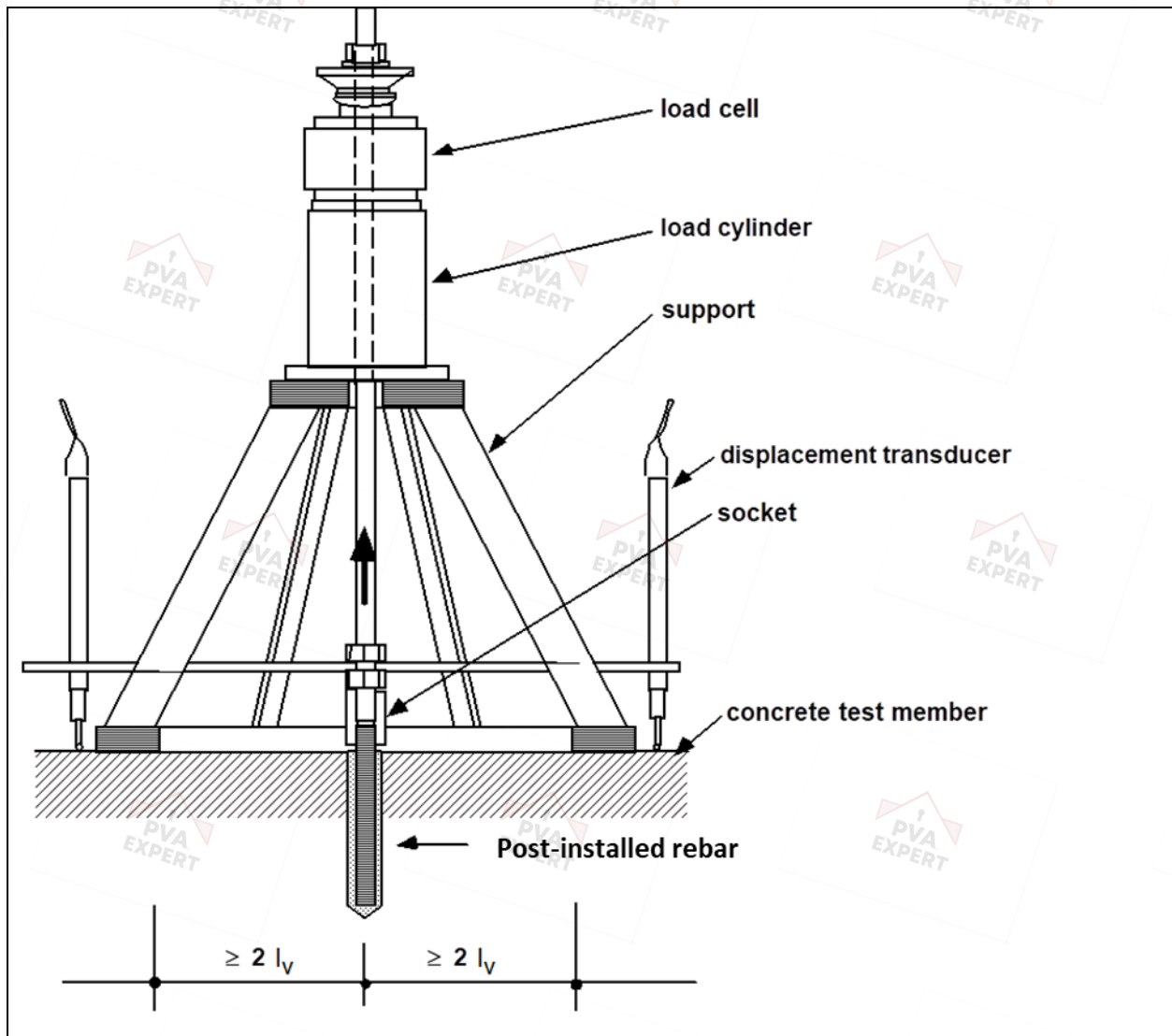

Figure B.3 Example of a tension test rig for unconfined tests

B.1.3 Confined test setup

Confined tests are performed when concrete cone failure shall be excluded. In confined tests concrete cone failure is eliminated by transferring the reaction force close to the rebar into the concrete.

An example of the test setup is shown in Figure B.4. The rig / steel plate shall be stiff and the area of support large to avoid high compression of the concrete. Recommendation: compression strength under the steel plate $< 0,7$ of the nominal concrete compression strength.

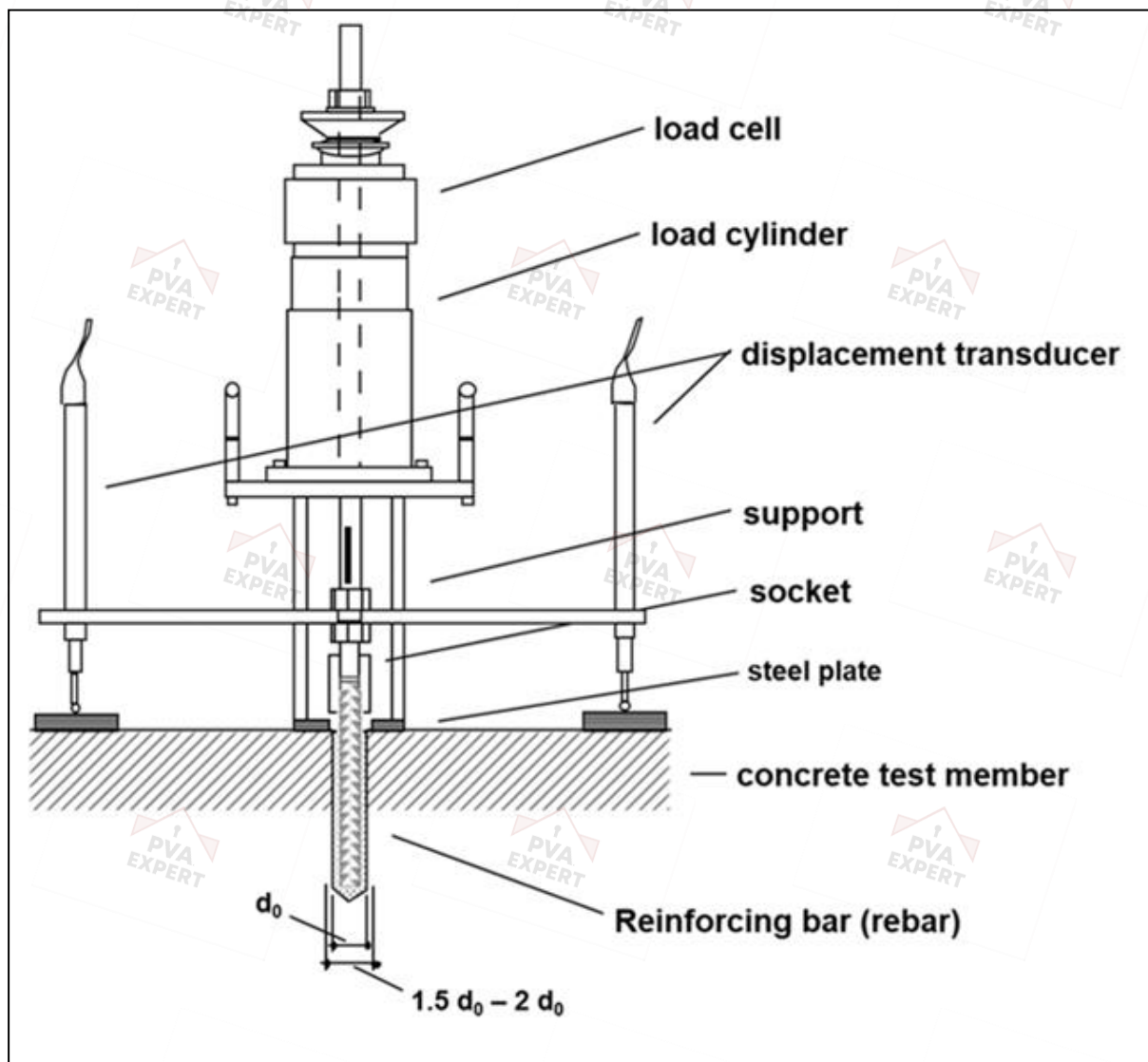

Figure B.4 Example of a tension test rig for confined tests

B.1.4 Installation of rebars

The tested rebars shall be installed in a concrete surface that has been cast against a form of the test member.

The rebars shall be installed in accordance with the manufacturer's product installation instructions (MPII), except where special conditions are specified in this EAD for a specific test series.

When testing in cracked concrete, rebars are placed in the middle of hairline cracks. It shall be verified that the rebar is placed over the entire anchoring zone in the crack by suitable methods (e.g., borescope).

The holes for rebars shall be perpendicular ($\pm 5^\circ$ deviation) to the surface of the concrete member.

In the tests the drilling tools specified by the manufacturer for the rebars shall be used.

The diameter of the drill bit shall be checked every 10 drilling operations to ensure continued compliance.

If the manufacturer's product installation instructions (MPII) allow any drilling method, the tests shall be performed with diamond drilling, which is the most critical case because of the smooth surface of the bore hole. It is allowed to establish different performance for different drilling techniques.

B.1.5 Test equipment

Tests shall be carried out using measuring equipment having a documented calibration according to international standards. The load application equipment shall be designed to avoid sudden increase in load especially at the beginning of the test. The measurement bias of the measuring chain of the load shall not exceed 2% of the measured quantity value.

Displacements shall be recorded continuously (e.g., by means of electrical displacement transducers) with a measuring bias not greater than 0,020 mm or 2,0 % for displacements > 1 mm.

For unconfined tests the test rigs shall allow the formation of an unrestricted rupture cone. For this reason, the distance between the support reaction and a rebar (single rebar) or an outer rebar (rebar group) respectively shall be at least $2 l_v$ (tension test) as shown in Figure B.3.

In tests on single rebars without edge and spacing influences the centre-to-centre distance and the distances from free edges shall be large enough to allow the formation of an unrestricted rupture cone of vertex angle 120° in the concrete.

During tension tests the load shall be applied concentrically to the rebar. To achieve this, hinges shall be incorporated between the loading device and the rebar. An example of a tension test rig is illustrated in Figure B.3.

B.2 Test procedure

B.2.1 General Aspects

The rebars shall be installed in accordance with section B1.4

The tests in cracked concrete are undertaken in unidirectional cracks. The required crack width Δw is given in Table A.1. Δw is the difference between the crack width when loading the rebar and the crack width at rebar installation. After installation of the rebar the crack is widened to the required crack width while the rebar is unloaded. The initial crack width shall be set to within +10 % of the specified value. However, the mean value of a series shall reflect the specified value.

Use one-sided tolerance for crack width.

Then the rebar is subjected to load while the crack width is controlled, either

- at a constant width, for example, by means of a servo system, or
- limited to a width close to the initial value by means of the reinforcement and depth of the test member.

In both cases the crack width at the face opposite to that through which the rebar is installed be maintained at a value larger than or equal to the specified value.

The load shall be increased in such a way that the peak load occurs after 1 to 3 minutes from commencement. Load and displacement shall be recorded continuously. The tests may be carried out with displacement or force control. In case of displacement control the test shall be continued beyond the peak of the load/displacement curve to at least 75 % of the maximum load to be measured (to allow the drop of the load/displacement curve). In case of displacement-controlled test setup the speed shall be kept constant.

The data shall be collected with a frequency of 3 Hz – 5 Hz.

B.2.2 Tension Tests

After installation, the rebar is connected to the test rig and loaded to failure. The displacements of the rebar relative to the concrete surface shall be measured by use of either one displacement transducer on the head of the rebar or by use of at least two displacement transducers on either side at a distance of $\geq 1,5 l_v$

from the rebar, unless otherwise specified for a specific test series. The mean value of the transducer readings shall be recorded in the case of two displacement transducers.

When testing rebars at the corner of a non-cracked test member, the test rig shall be placed such that an unrestricted concrete failure towards the corner is possible (see Figure B.9). It may be necessary to support the test rig outside the test member.

When testing in cracked concrete, the crack width shall be regularly measured during the test on both sides of the rebar at a distance of approximately $1,0 l_v$ and at least on the face of the test member in which the rebars are installed.

B.3 Test Specimen for Resistance to Seismic Loading

B.3.1 Test Specimen 1 – Pull-out tests

Unreinforced concrete slabs are used as pull-out-specimen. The minimum dimensions of the specimen are shown in Figure 2.5 as an example. If two (or more) tests are performed in the same slab, the distance between two tests shall be at least $4l_v$. Before casting of the pull-out specimen tubes (PIR) with the same nominal diameter shall be prepared as described in section 2.2.5 and securely fastened to the formwork.

B.3.2 Test Specimen 2 – Beam End Tests (BET)

B.3.2.1 Dimensions

For the splitting tests a beam-end-test specimen is used. A schematic drawing of the BET specimen is given in Figure B.5. Two tests can be performed with one specimen. Before casting of the BET specimen tubes (post-installed - PIR) or rebar (cast-in rebar - CI) with the same nominal diameter shall be prepared as described in section A.3 and securely fastened to the formwork.

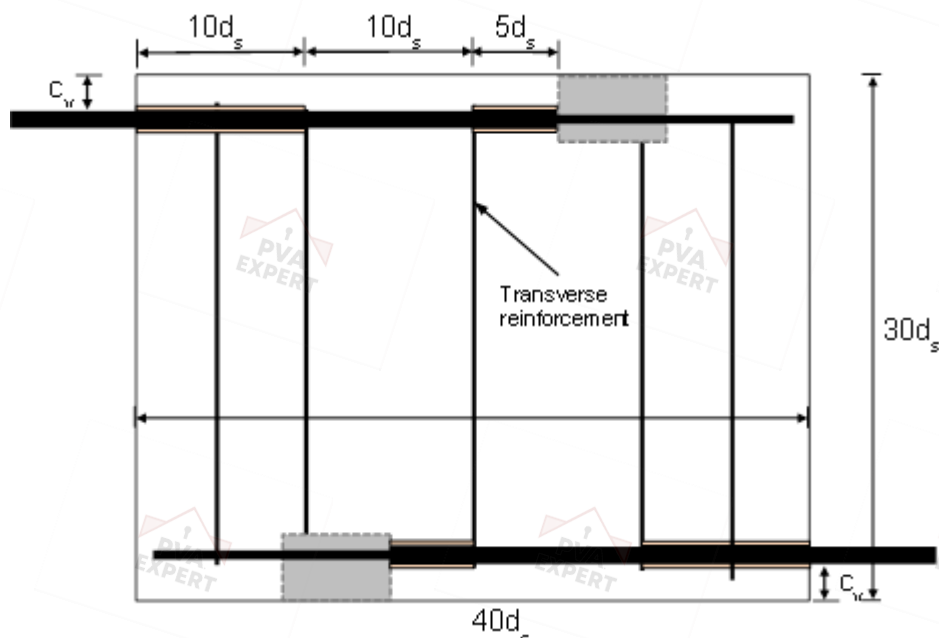

Figure B.5: Schematic drawing of BET-Specimen

B.3.2.2 Reinforcement Details

Detailed drawings of the specimen and the reinforcement are provided in Figure 2.7 and Figure B.6.

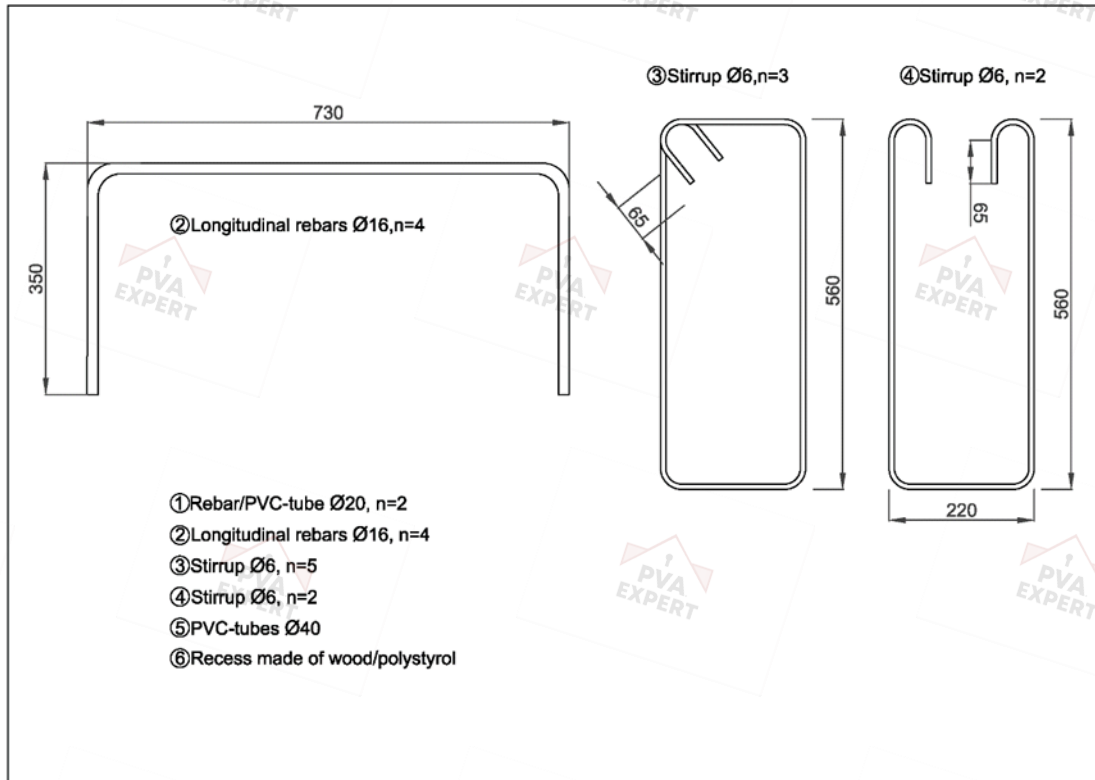

Figure B.6: Reinforcement of BET-specimen for testing performed with $\phi = 20$ mm

B.3.2.3 Preparation of cast-in (CI) rebars and tubes for post-installed rebars (PIR)

For tests on cast-in rebars, the rebar is positioned before casting of the specimen. In case of a post installed rebar a tube (e.g., made of PVC) is cast in instead in order to create a pilot hole to avoid deviations of the borehole axis during drilling. In both test specimens the rebars show three different parts (see Figure B.7), an initial debonded length (l_{db1}), followed by the bond length (l_b) and another debonded length at the rear end (l_{db2}). Before casting both rebar and tube are prepared in the same way. The steps of preparation of the rebars/tubes are described in Table B.1.

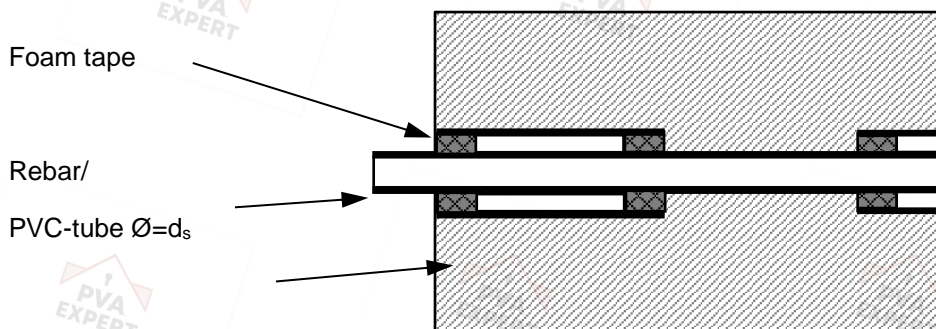





Figure B.7: Bonded and debonded parts of the rebars in the test specimen

Table B.1: Preparation of cast in rebars/tubes

<p>In the debonded parts the rebar/tube is covered by a tube with diameter of approximately 2 times the rebar diameter. The distance between the rebar/tube and the larger tubes in the debonded parts is sealed with a foam tape.</p>	
<p>The foam tape for CI rebars can be adhered directly to the rebar.</p> <p>In case of PIR, the foam tape can only be directly adhered to the inner tube in the initial debonded length (l_{db1}). In the second debonded length (l_{db2}), the foam tape needs to be movable on the tube surface, because the tube is pulled out before curing of the concrete.</p>	
<p>After preparation, the rebars/tubes are installed in the formwork. The covering tube of l_{db2} can be fixed at the recess. Therefore, it is recommended to use a wooden panel at least for this surface of the recess.</p>	
<p>To ensure secure positioning the covering tube of l_{db1} can go through a hole in the formwork.</p>	





B.3.2.4 Casting of specimens

Before casting, all dimensions need to be checked, especially the thickness of the concrete cover and correct length and position of the bonded and debonded parts. When the concrete is poured in the formwork it **shall** not directly fall on the installed tubes/rebars, to ensure that they stay in the correct position. During cast-in of the specimen, the concrete **shall** be properly compacted with internal vibrators. This needs to be conducted very carefully, because the vibrator **shall** not touch the installed rebars/tubes. The tubes that were installed to create a pilot hole for PIR **shall** be removed after the concrete starts to cure.

B.3.2.5 Preparation of post-installed rebars PIR

Before installation of the PIR, they are prepared in the following manner in order to create clearly defined bonded and debonded parts for the PIR: (All steps of the preparation are shown in Table B.2).



Table B2: Preparation of post-installed rebars PIR

<p>Along the debonded part at the backside (l_{db2}) the ribs of the rebar are removed by turning using a lathe and hence the diameter of the rebar is reduced</p>	
<p>The smoothed (e.g., reduced area) portion of the rebar is covered with a PVC tube of the nominal diameter of the rebar. During installation no mortar shall flow between rebar and tube. In some cases, it might therefore be necessary to adjust the diameter of the reduced part of the rebars to account for differences in the inner diameter of the tube using adhesive tape.</p>	
<p>The debonded part at the front side (l_{db1}) of the rebar is covered with a tube with a nominal diameter corresponding to the nominal drill bit diameter and sealed with hot melting glue.</p>	 
<p>An additional layer of adhesive foam tape can be applied around this tube.</p>	

B.3.2.6 Installation procedure of post-installed rebars PIR

All steps of the installation of PIR are explained in Table B.3. The flow of the adhesive (red colour) is schematically shown in Figure B.8. With this procedure at least one weak layer between rebars and concrete is provided in both debonded parts. Thus, the load transfer in the debonded parts is reduced to a minimum for tension and compression loading, no matter if the failure of the bond happens between steel and mortar or between mortar and concrete.

Table B.3: Description of the installation procedure

<p>Drilling of the borehole. The pilot hole formed by the tube during casting is enlarged by drilling. A special rig shall be used to ensure that the hole is drilled perpendicular to the concrete surface. This technique, in addition to the provided pilot hole, ensures the correct borehole position. The pilot hole helps to reduce spalling at the end of the borehole significantly</p> <p>After drilling, prior to the bore hole cleaning it shall be checked if the foam tape, which stayed in the concrete in debonded part l_{db2}, is completely removed. If it is not the case the tape shall be removed manually.</p>	
<p>Bore hole cleaning in accordance with the manufacturer's product installation instruction (MPII).</p>	
<p>Prior to injection of the mortar, a cylinder made of polystyrene shall be inserted in the tube at the unloaded end of the rebar (l_{db2}). Afterwards, the backside of the hole is sealed with a block of polystyrene.</p>	

	
<p>The mortar is injected using a dispenser and a rebar prepared as explained in Section B2.5 can be installed.</p>	

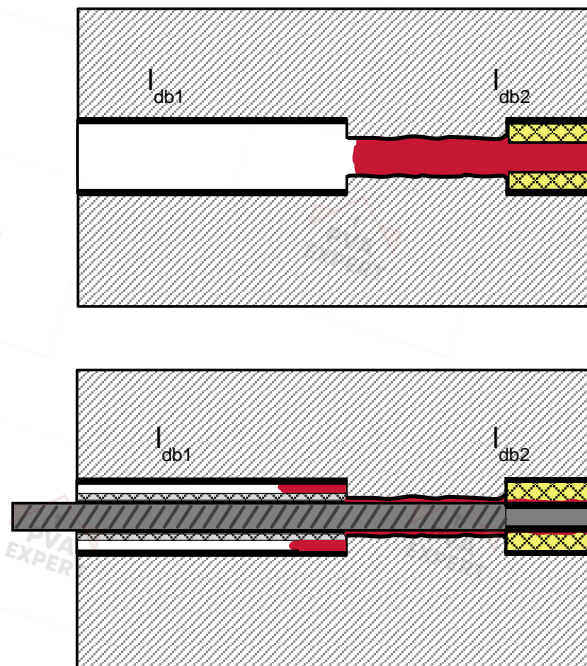

Figure B.8: Installation procedure (flow of the adhesive)

B.4 Test Report

Since only relevant parameter shall be followed for each test series this table is meant as a check list. The test report shall include at least the relevant information for the particular test series.

1. Description test specimen		
Rebar type	Manufacturer, trade name, dimensions, nominal ultimate strength, yield strength	
status of specimen	serial product / prototype	
production lot / batch		
Mortar	Designation, size of package, type of cartridge	xy injection mortar – fast curing version, side by side cartridge xxx ml
	Mass of components, density, viscosity, reactivity, infrared analysis	
	Type of dispenser and other tools, if any	e.g., Manual dispenser xy, piston plug size xx
2. Test member		
element type / drawing no.	sketch according to "examples cross section" and "example for test member with bond breaking pipes"	
Dimensions	(l / w / h)	
concrete mix	e.g., cement, aggregate type and content, w/c-ratio	
curing conditions		
age of concrete member at time of testing		

type and grade of reinforcement	
longitudinal reinforcement quantity.	
longitudinal reinforcement size	
pre-debonding length	
type of bond breaker sheets	e.g., wood/ plastic/ metal/ none
reinforcement spacing	e.g., 254 mm horizontal, 50 mm from edges
distribution of reinforcement over depth of member	e.g., two rows, 100 mm from top and bottom
reinforcement is distributed double symmetrically	
3. Setting/ Installation information	
member thickness h,	
Embedment depth l_v	
place of rebar installation	formwork side
type/ diameter of support	confined / unconfined $d = 450$ mm
spacing between post-installed rebar and cast-in rebar of the test member	200 mm
drilling in hairline crack	yes / no
drill hole prepared separately before each test	yes / no
Drilling method	
Type of drilling machine	
Type and cutting diameter of drill bit	
For stop drills: length of drill bit	
Tools for cleaning of drill holes (if relevant)	
borehole depth h_1 [mm]	
borehole cleaning procedure (if any)	
position of the rebar over load transfer zone in the crack	sketch
verification method of rebar position in crack	e.g., borescope (sketch of crack formation over load transfer zone)
4. Test parameter	
crack opening mechanism	Describe how the crack width in the area of the load transfer zone is ensured
loading/ unloading rates [sec.]	e.g., 2,5 / 2,5
nominal sustained load	e.g., 10 kN
min. sustained load	10,1 kN
max. sustained load	10,9 kN
mean sustained load	10,3 kN
no. of replicates tested simultaneously	e.g., one
measuring of rebar displacement	e.g., continuously / at the rebar
no. of replicates tested in one specimen/ crack	e.g., 6 per specimen / 2 per crack
amount / type of crack width measurement	e.g., 4 / capacitive sensor
position of the crack width sensors	sketch with distances
determination of crack width at rebar	e.g., (linear interpolation)

Diagram containing: <ul style="list-style-type: none"> - crack width at the rebar position for the top and bottom of the load transfer zone - plot the cycles in normal logarithmic scale - plot the upper and the lower crack width 	
measuring uncertainty for crack width transducers	e.g., $\pm 0,005$ mm
minimal frequency during the test	
maximal frequency during the test	
5. Test results	
Load at failure	
Load at loss of adhesion	
Displacement at failure	
Diagram with load displacement curve	
Failure mode (If initial failure is not clear, a combination of failure modes may be reported.)	<ul style="list-style-type: none"> - (cc) concrete cone failure – give diameter and depth of concrete cone - (sp) splitting– test condition for tests in uncracked concrete in case when a first crack of the concrete is observed - (po) pull-out – pull-out failure may be combined with a shallow concrete breakout - (s) steel failure– define position of the steel rupture of the rebar - (pr) pry-out – concrete breakout opposite to the load direction (may occur for shallow embedment) - (be) bond – element failure - (bbe) bond – borehole failure
Diagram with displacement over time of testing (long-term tests only)	